



# ALLIED MACHINE & ENGINEERING

Holemaking Solutions for Today's Manufacturing



Drilling



Reaming



Burnishing



Threading



Specials



## Wohlhaupter®

► *BORING*

Versatile Fine Boring

**WOHLHAUPTER®**



SECTION

---

# B10-A

---

Versatile Fine Boring

# Wohlhaupter® Versatile Fine Boring

VarioBore | 249 (248) | PrimeBore | Digital 511 (510) | DigiBore

► Diameter Range: 0.016" - 8.189" (0.40 mm - 208.00 mm)



## WOHLHAUPTER®

Precision boring at its finest.

From high precision to high production, Wohlhaupter has the right solution for your hole finishing applications. With the most reliable digital readout displays, the Wohlhaupter versatile boring product line offers the most precise and flexible modular system on the market.

### Applicable Industries



Aerospace



Agriculture



Automotive



Firearms



General  
Machining



Oil & Gas



Renewable  
Energy

Your safety and the safety of others is very important. This catalog contains important safety messages. Always read and follow all safety precautions.



This triangle is a safety hazard symbol. It alerts you to potential safety hazards that can cause tool failure and serious injury.

When you see this symbol in the catalog, look for a related safety message that may be near this triangle or referred to in the nearby text.

There are safety signal words also used in the catalog. Safety messages follow these words.

**WARNING** (shown above) means that failure to follow the precautions in this message could result in tool failure and serious injury.

**NOTICE** means that failure to follow the precautions in this message could result in damage to the tool or machine but not result in personal injury.

**NOTE** and **IMPORTANT** are also used. These are important that you read and follow but are not safety-related.

Visit [www.alliedmachine.com](http://www.alliedmachine.com) for the most up-to-date information and procedures.



### Reference Icons

The following icons will appear throughout the catalog to help you navigate between products.

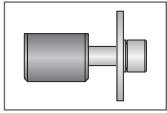

**Clamping Elements**  
For use with insert holders and boring heads

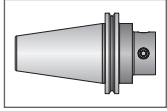

**Shanks**  
A variety of shanks for different machines

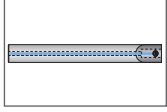

**249 (248) Shanks**  
A variety of shanks for different machines

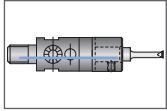

**249 (248) Boring Head**  
249 (248) boring head that connects into the adapter shanks

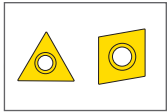

**Inserts**  
For use with insert holder boring heads and boring bars using indexable inserts

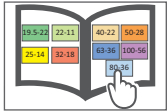

**MVS Connection Color Guide**  
Detailed instructions and information regarding the MVS connection(s)

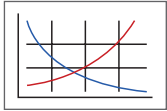

**Recommended Cutting Data**  
Speed and feed recommendations for optimum and safe boring



**Coolant-Through Option**  
Indicates that the product is coolant-through

Series	Diameter Range	
	Imperial (inch)	Metric (mm)
VarioBore 563 (536)	0.016 - 5.984	0.40 - 152.00
249 (248) Boring Head	0.118 - 1.189	3.00 - 30.20
PrimeBore 451 (450)	0.118 - 8.189	3.00 - 208.00
Digital 511 (510)	0.016 - 1.339	0.40 - 12.00
DigiBore 504 (501)	0.118 - 8.189	3.00 - 208.00

## Versatile Fine Boring Contents

### VarioBore

Product Overview	2 - 3
Boring Heads	4 - 5
Boring Bars	6 - 10
Serrated Tool Bodies   Insert Holders	11 - 12
Serrated Slides   Insert Holders	13
Insert Holders for Boring Heads	14
Outside Turning Tools	15 - 16
Reducing Sleeves	17
Accessories	18 - 19
VarioBore Kits	20 - 27

### 249 (248)

Product Overview	28 - 29
Boring Heads	30
Boring Bars	31 - 32
Adapters	33
Shanks	34
Accessories	35

### PrimeBore

Product Overview	36 - 37
Boring Heads	38
Boring Bars	39 - 40
Serrated Tool Bodies   Insert Holders	42
Serrated Slides   Insert Holders	43 - 44
Outside Turning Tools	45 - 46
Accessories	47
PrimeBore Kits	48 - 49

### Digital 511 (510)

Product Overview	50 - 51
Boring Heads   Reducing Sleeves	52
Boring Bars	53 - 56
Serrated Tool Bodies   Insert Holders	57
Accessories	58

### DigiBore

Product Overview	60 - 61
Boring Heads	62
Boring Bars	63 - 65
Serrated Tool Bodies   Insert Holders	66 - 67
Serrated Slides   Insert Holders	68
Outside Turning Tools	69 - 70
Accessories	71 - 72
DigiBore Kits	73 - 80

# VarioBore Product Overview

## VarioBore with 3E<sup>TECH</sup>+ VERSATILE FINE BORING

### Need more versatility?

The Wohlhaupter® VarioBore head offers precision and versatility, and the 3E<sup>TECH</sup>+ docking port provides convenient and simple diameter adjustments.

Experience *precision boring* for yourself.

- Diameter range: 0.016" - 5.984" (0.40 mm - 152.00 mm)
- Offers outside turning capabilities: 0.079" - 2.598" (2.00 mm - 66.00 mm)
- Ease the stress of working on different day-to-day projects with boring kits
- 3E<sup>TECH</sup>+ module provides a simple digital readout
- Max spindle speed: 27,500 RPM



**NOTE:** 3E<sup>TECH</sup>+ adjustment accuracy of 0.0001" or 0.001 mm on diameter

**NOTE:** Vernier adjustment accuracy of 0.0001" or 0.002 mm on diameter

**IMPORTANT:** Max spindle speed refers to maximum possible speed for an individual boring head and is not a recommended parameter. Refer to page B10-M: 12 for recommended application-specific parameters. Factory technical assistance is available for your specific applications through our Application Engineering department.  
ext: 7611 | email: [appeng@alliedmachine.com](mailto:appeng@alliedmachine.com)





3E<sup>TECH+</sup>  
Universal Digital  
Module



VarioBore Head

# VARIO BORE

with **3E<sup>TECH+</sup>** Universal Digital  
Readout Module

**NOTE:** Imperial items pictured

**NOTE:** 3E<sup>TECH+</sup> adjustment accuracy of 0.0001" or 0.001 mm on diameter

**NOTE:** Vernier adjustment accuracy of 0.0001" or 0.002 mm on diameter

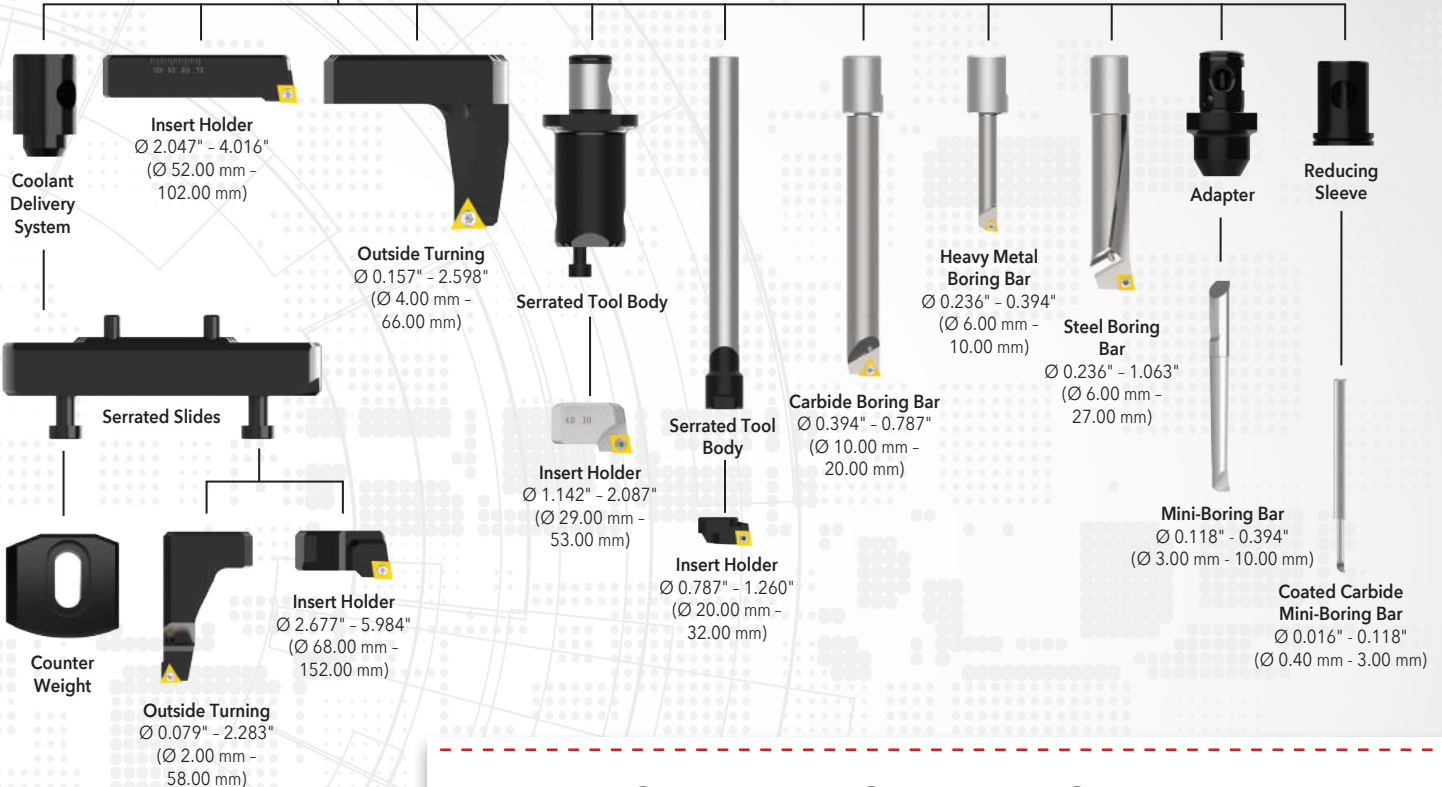

## OPERATION **VERSATILITY**

from **0.016"** to **5.984"** (0.40 mm to 152.00 mm)  
*plus outside turning*



**NOTE:** Imperial items pictured

**NOTE:** 3E<sup>TECH+</sup> adjustment accuracy of 0.0001" or 0.001 mm on diameter

**NOTE:** Vernier adjustment accuracy of 0.0001" or 0.002 mm on diameter

## Digital 3E<sup>TECH+</sup> Boring Heads

Diameter Range: 0.016" - 5.984" (0.40 mm - 152.00 mm)

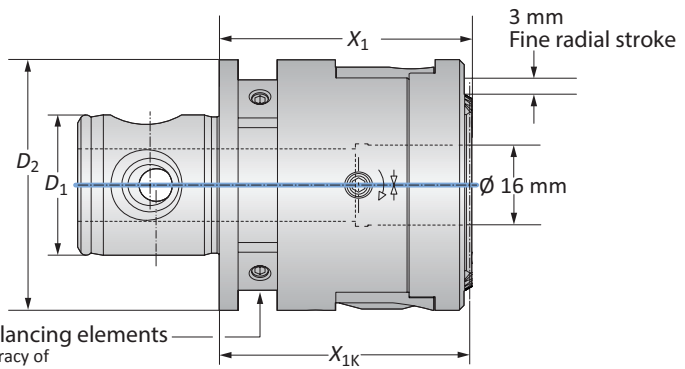

NOTE: Vernier adjustment accuracy of 0.0001" or 0.002 mm on diameter

### VarioBore Digital 3E<sup>TECH+</sup> Boring Head

	MVS Connection		Boring Head		Weight	Part No.
	D <sub>2</sub>   D <sub>1</sub>	Boring Range	X <sub>1</sub>	X <sub>1K</sub>		
<b>i</b>	50 - 28	0.016 - 5.984	1.969	1.949	1.543 (lbs)	<b>563002</b>
<b>m</b>	50 - 28	0.40 - 152.00	50.00	49.50	0.70 (kg)	<b>536002</b>

NOTE: Balancing elements, 3E<sup>TECH+</sup> digital readout module, and charging unit must be ordered separately.  
 NOTE: VarioBore heads are compatible with Kaiser® connection

### 3E<sup>TECH+</sup> Digital Readout Module

Part No.	Charging Unit*
536015	536016

NOTE: WEEE-Reg.-Nr. DE 15820388  
 \*Charging unit sold separately



NOTE: 3E<sup>TECH+</sup> adjustment accuracy of 0.0001" or 0.001 mm on diameter

Key on B10-A: 1

B10-M: 12-15

B10-F

B10: vi-vii

**i** = Imperial (in)  
**m** = Metric (mm)

**IMPORTANT:** Max spindle speed refers to maximum possible speed for an individual boring head and is not a recommended parameter. Refer to page B10-M: 12 for recommended application-specific parameters. Factory technical assistance is available for your specific applications through our Application Engineering department.  
 ext: 7611 | email: [appeng@alliedmachine.com](mailto:appeng@alliedmachine.com)

## Nondigital Boring Heads

Diameter Range: 0.016" - 5.984" (0.40 mm - 152.00 mm)

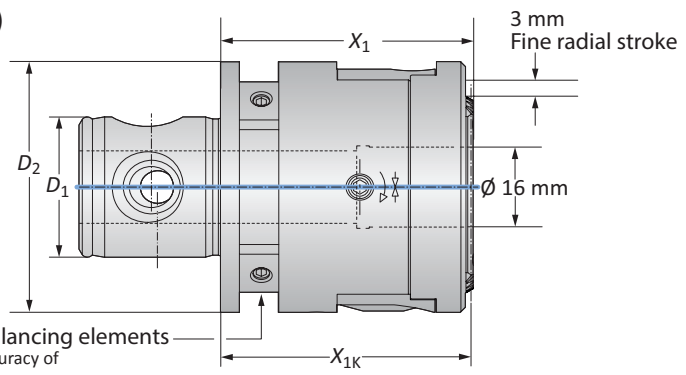

NOTE: Vernier adjustment accuracy of 0.0001" or 0.002 mm on diameter

### VarioBore Nondigital Boring Head

	MVS Connection		Boring Head		Weight	Part No.
	$D_2$   $D_1$	Boring Range	$X_1$	$X_{1K}$		
<b>i</b>	50 - 28	0.016 - 5.984	1.969	1.949	1.543 (lbs)	<b>563001</b>
<b>m</b>	50 - 28	0.40 - 152.00	50.00	49.50	0.70 (kg)	<b>536001</b>

NOTE: Balancing elements must be ordered separately.

NOTE: VarioBore heads are compatible with Kaiser® connection

B10-M: 12-15

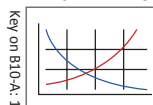

B10-F

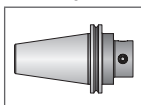

B10: vi-vii

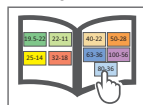

Key on B10-A-1

**i** = Imperial (in)  
**m** = Metric (mm)

**IMPORTANT:** Max spindle speed refers to maximum possible speed for an individual boring head and is not a recommended parameter. Refer to page B10-M: 12 for recommended application-specific parameters. Factory technical assistance is available for your specific applications through our Application Engineering department.  
ext: 7611 | email: [appeng@alliedmachine.com](mailto:appeng@alliedmachine.com)

A  
B  
C  
D  
E  
F  
G  
H  
I  
J  
K  
L  
M  
INDEX



## Mini Boring Bars

WHC126 Coated Carbide | Diameter Range: 0.016" - 0.118" (0.40 mm - 3.00 mm)

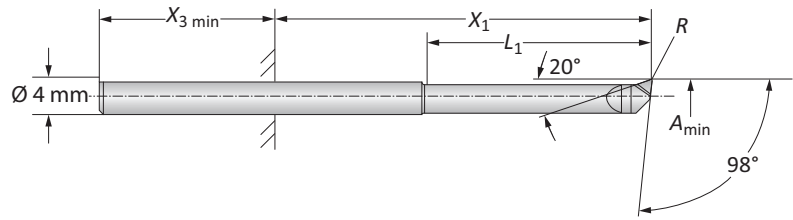

### Mini Boring Bars

	Boring Range		Boring Bar*			Part No.
	$A_{min}$	$X_1$	$X_{3\ min}$	$L_1$	$R$	
i	0.016	0.118 - 0.669	0.980	0.079	0.0010	081401WHC126
	0.024	0.157 - 0.709	0.980	0.118	0.0020	081402WHC126
	0.031	0.197 - 0.748	0.980	0.157	0.0020	081403WHC126
	0.039	0.236 - 0.787	0.980	0.197	0.0025	081404WHC126
	0.059	0.335 - 0.886	0.980	0.295	0.0025	081405WHC126
	0.079	0.433 - 0.984	0.980	0.394	0.0025	081406WHC126
	0.098	0.531 - 1.083	0.980	0.492	0.0025	081407WHC126
	0.110	0.591 - 1.142	0.980	0.551	0.0030	081408WHC126
m	0.40	3.00 - 17.00	25.00	2.00	0.03	081401WHC126
	0.60	4.00 - 18.00	25.00	3.00	0.04	081402WHC126
	0.80	5.00 - 19.00	25.00	4.00	0.04	081403WHC126
	1.00	6.00 - 20.00	25.00	5.00	0.05	081404WHC126
	1.50	8.50 - 22.50	25.00	7.50	0.05	081405WHC126
	2.00	11.00 - 25.00	25.00	10.00	0.05	081406WHC126
	2.50	13.50 - 27.50	25.00	12.50	0.05	081407WHC126
	2.80	15.00 - 28.00	25.00	14.00	0.07	081408WHC126

\*Fixture-through reducing sleeve (B10-A: 17)

B10-M: 12-15

B10: vi-vii

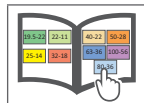
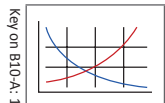

i = Imperial (in)  
m = Metric (mm)

## Mini Boring Bars

WHC05 | WHW04 | WBN150 | Diameter Range: 0.118" - 0.394" (3.00 mm - 10.00 mm)

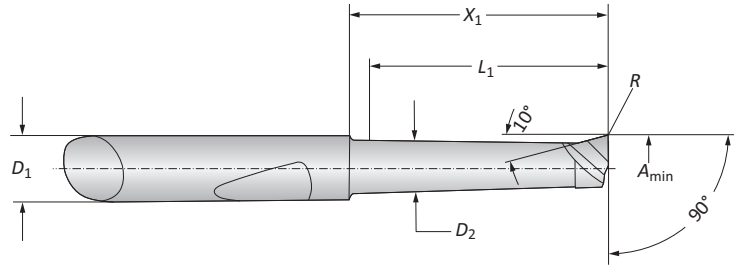

### Mini Boring Bars

Boring Range	Boring Bar						Part No.		
	$A_{min}$	$D_1$	$D_2$	$X_1$	$L_1$	$R$	Coated Carbide	Uncoated Carbide	CBN
i	0.118	0.236	0.102	0.452	0.393	0.003	081306WHC05	-	081322WBN150
	0.118	0.236	0.102	0.649	0.590	0.003	081307WHC05	081307WHW04	-
	0.157	0.236	0.141	0.472	0.393	0.007	081308WHC05	-	081317WBN150
	0.157	0.236	0.141	0.669	0.590	0.007	081309WHC05	-	081341WBN150
	0.157	0.236	0.141	0.866	0.787	0.007	081310WHC05	081310WHW04	-
	0.196	0.236	0.181	0.472	0.393	0.007	081311WHC05	-	081318WBN150
	0.196	0.236	0.181	0.866	0.787	0.007	081312WHC05	-	081319WBN150
	0.196	0.236	0.181	1.259	1.181	0.007	081313WHC05	081313WHW04	-
	0.236	0.236	0.220	0.866	0.787	0.007	081314WHC05	-	081320WBN150
	0.236	0.236	0.220	1.259	1.181	0.007	081315WHC05	-	081321WBN150
	0.236	0.236	0.220	1.653	1.574	0.007	081316WHC05	081316WHW04	-
	0.315	0.315	0.229	0.984	0.905	0.007	081323WHC05	-	-
	0.315	0.315	0.229	1.968	1.889	0.007	081324WHC05	-	-
	m	3.00	6.00	2.60	11.50	10.00	0.10	081306WHC05	-
3.00		6.00	2.60	16.50	15.00	0.10	081307WHC05	081307WHW04	-
4.00		6.00	3.60	12.00	10.00	0.20	081308WHC05	-	081317WBN150
4.00		6.00	3.60	17.00	15.00	0.20	081309WHC05	-	081341WBN150
4.00		6.00	3.60	22.00	20.00	0.20	081310WHC05	081310WHW04	-
5.00		6.00	4.60	12.00	10.00	0.20	081311WHC05	-	081318WBN150
5.00		6.00	4.60	22.00	20.00	0.20	081312WHC05	-	081319WBN150
5.00		6.00	4.60	32.00	30.00	0.20	081313WHC05	081313WHW04	-
6.00		6.00	5.60	22.00	20.00	0.20	081314WHC05	-	081320WBN150
6.00		6.00	5.60	32.00	30.00	0.20	081315WHC05	-	081321WBN150
6.00		6.00	5.60	42.00	40.00	0.20	081316WHC05	081316WHW04	-
8.00		8.00	7.60	25.00	23.00	0.20	081323WHC05	-	-
8.00		8.00	7.60	50.00	48.00	0.20	081324WHC05	-	-



### Adapters

Boring Range	Adapter				Part No.	
	$A_{min}$	$D_3$	$D_5$	$X_1$		
m	3.00	6.00	20.00	22.50	14.00	319010
	8.00	8.00	22.00	22.50	14.00	236071

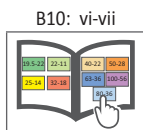
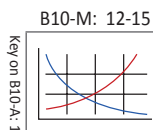
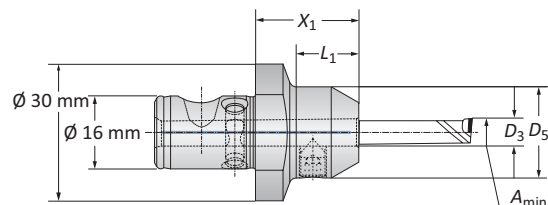

i = Imperial (in)  
m = Metric (mm)

A  
B  
C  
D  
E  
F  
G  
H  
I  
J  
K  
L  
M  
INDEX

## Boring Bars

Steel | Diameter Range: 0.236" - 1.063" (6.00 mm - 27.00 mm)



Form 101

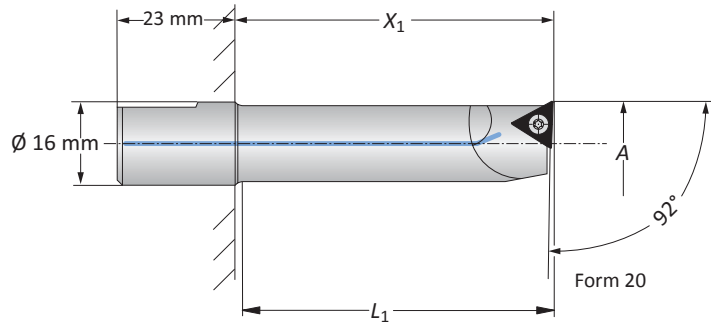

Boring Range	Boring Bar			Weight	Insert Form	Part No.	Insert Form	Part No.
	A	X <sub>1</sub>	L <sub>1</sub>					
0.236 - 0.315	0.866	0.748	0.070 (lbs)	-	-	211*	081053	
0.315 - 0.394	1.181	1.063	0.090 (lbs)	-	-	211*	218071	
0.394 - 0.472	1.772	1.654	0.110 (lbs)	-	-	20*	081044	
0.394 - 0.472	0.984	0.866	0.090 (lbs)	101	218047	20*	218058	
0.394 - 0.472	1.378	1.260	0.110 (lbs)	101	218048	20*	218059	
0.472 - 0.551	1.181	1.063	0.110 (lbs)	101	218012	20*	218014	
0.472 - 0.551	1.772	1.654	0.130 (lbs)	101	218049	20*	218060	
0.551 - 0.630	1.378	1.260	0.130 (lbs)	101	218050	20*	218061	
<b>i</b> 0.551 - 0.630	1.969	1.850	0.180 (lbs)	101	218051	20*	218062	
0.591 - 0.669	1.457	1.339	0.130 (lbs)	-	-	20*	081048	
0.591 - 0.669	2.362	2.244	0.180 (lbs)	101	081041	20*	081045	
0.630 - 0.786	1.575	1.457	0.180 (lbs)	101	218052	20*	218063	
0.630 - 0.786	2.362	2.244	0.200 (lbs)	101	218053	20*	218064	
0.787 - 0.984	1.457	1.339	0.150 (lbs)	-	-	20*	081049	
0.787 - 0.984	2.756	2.638	0.240 (lbs)	101	081042	20*	081046	
0.984 - 1.063	1.457	1.339	0.150 (lbs)	-	-	20*	081050	
0.984 - 1.063	2.756	2.638	0.240 (lbs)	101	081043	20*	081047	
<hr/>								
6.00 - 8.00	22.00	19.00	0.03 (kg)	-	-	211*	081053	
8.00 - 10.00	30.00	27.00	0.04 (kg)	-	-	211*	218071	
10.00 - 12.00	45.00	42.00	0.05 (kg)	-	-	20*	081044	
10.00 - 12.00	25.00	22.00	0.04 (kg)	101	218047	20*	218058	
10.00 - 12.00	35.00	32.00	0.05 (kg)	101	218048	20*	218059	
12.00 - 14.00	30.00	27.00	0.05 (kg)	101	218012	20*	218014	
12.00 - 14.00	45.00	42.00	0.06 (kg)	101	218049	20*	218060	
14.00 - 16.00	35.00	32.00	0.06 (kg)	101	218050	20*	218061	
<b>m</b> 14.00 - 16.00	50.00	47.00	0.08 (kg)	101	218051	20*	218062	
15.00 - 17.00	37.00	34.00	0.06 (kg)	-	-	20*	081048	
15.00 - 17.00	60.00	57.00	0.08 (kg)	101	081041	20*	081045	
16.00 - 20.00	40.00	37.00	0.08 (kg)	101	218052	20*	218063	
16.00 - 20.00	60.00	57.00	0.09 (kg)	101	218053	20*	218064	
20.00 - 25.00	37.00	34.00	0.07 (kg)	-	-	20*	081049	
20.00 - 25.00	70.00	67.00	0.11 (kg)	101	081042	20*	081046	
25.00 - 27.00	37.00	34.00	0.07 (kg)	-	-	20*	081050	
25.00 - 27.00	70.00	67.00	0.11 (kg)	101	081043	20*	081047	

\*Not suitable for indexable inserts with a radius of 0.031" (0.80 mm)

B10-M: 12-15

B10-H

B10: vi-vii

Key on B10-A:1

**i** = Imperial (in)  
**m** = Metric (mm)

Inserts sold separately

## Boring Bars

Heavy Metal | Carbide | Diameter Range: 0.236" - 0.787" (6.00 mm - 20.00 mm)

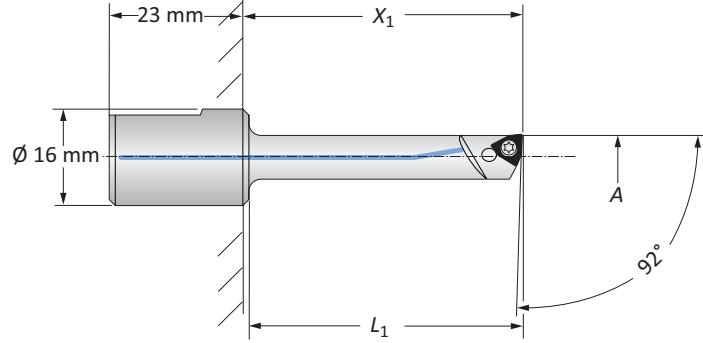

Heavy Metal Boring Bars | Diameter Range: 0.236" - 0.394" (6.00 mm - 10.00 mm)

	Boring Range		Boring Bar		Weight	Insert Form	Part No.
	A	X <sub>1</sub>	L <sub>1</sub>				
i	0.236 - 0.315	1.260	1.142	0.176 (lbs)	211*	081055	
	0.315 - 0.394	1.772	1.654	0.198 (lbs)	211*	218072	
m	6.00 - 8.00	32.00	29.00	0.08 (kg)	211*	081055	
	8.00 - 10.00	45.00	42.00	0.09 (kg)	211*	218072	

\*Not suitable for indexable inserts with a radius of 0.031" (0.80 mm)



Form 101

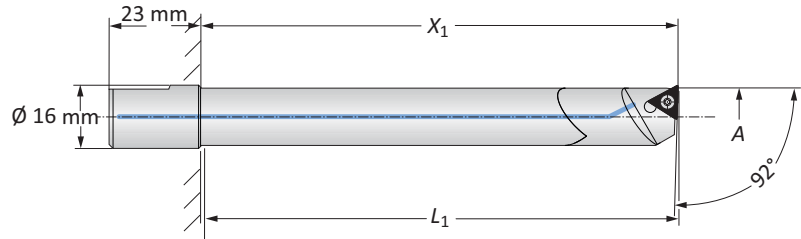

Form 20

Carbide Boring Bars | Diameter Range: 0.394" - 0.787" (10.00 mm - 20.00 mm)

	Boring Range		Boring Bar		Weight	Insert Form	Part No.	Insert Form	Part No.
	A	X <sub>1</sub>	L <sub>1</sub>						
i	0.394 - 0.472	2.165	2.047	0.154 (lbs)	101	218042	20	218037*	
	0.394 - 0.472	2.953	2.835	0.198 (lbs)	101	218032	20	218029*	
	0.472 - 0.551	2.756	2.638	0.220 (lbs)	101	218043	20	218038*	
	0.472 - 0.551	3.543	3.425	0.331 (lbs)	101	218033	20	218030*	
	0.551 - 0.630	2.953	2.835	0.353 (lbs)	101	218044	20	218039*	
	0.551 - 0.630	3.937	3.819	0.441 (lbs)	101	218045	20	218040*	
	0.630 - 0.787	3.543	3.425	0.573 (lbs)	101	218046	20	218041*	
m	0.630 - 0.787	4.724	4.606	0.728 (lbs)	101	218034	20	218031*	
	10.00 - 12.00	55.00	52.00	0.07 (kg)	101	218042	20	218037*	
	10.00 - 12.00	75.00	72.00	0.09 (kg)	101	218032	20	218029*	
	12.00 - 14.00	70.00	67.00	0.10 (kg)	101	218043	20	218038*	
	12.00 - 14.00	90.00	87.00	0.15 (kg)	101	218033	20	218030*	
	14.00 - 16.00	75.00	72.00	0.16 (kg)	101	218044	20	218039*	
	14.00 - 16.00	100.00	97.00	0.20 (kg)	101	218045	20	218040*	
	16.00 - 20.00	90.00	87.00	0.26 (kg)	101	218046	20	218041*	
	16.00 - 20.00	120.00	117.00	0.33 (kg)	101	218034	20	218031*	

\*Not suitable for indexable inserts with a radius of 0.031" (0.80 mm)

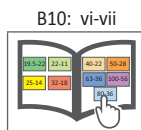
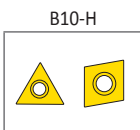
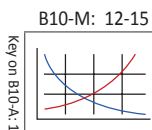

i = Imperial (in)  
m = Metric (mm)  
Inserts sold separately

## Boring Bars

Steel | Carbide | Diameter Range: 0.236" - 0.787" (6.00 mm - 20.00 mm)

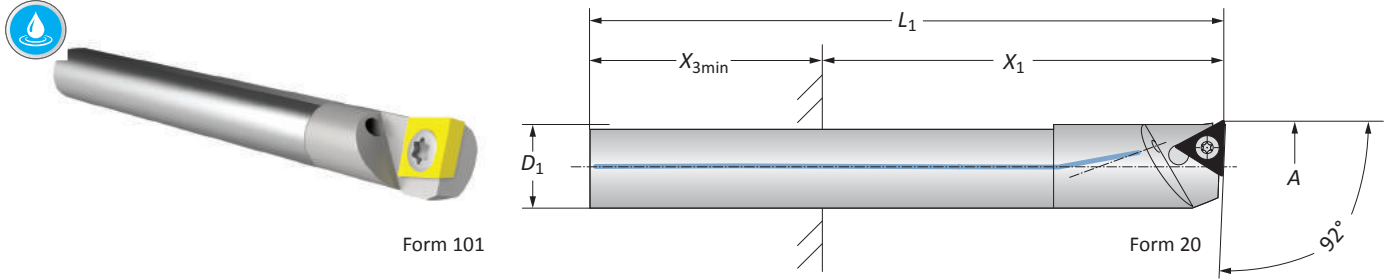

Steel Boring Bars | Diameter Range: 0.236" - 0.787" (6.00 mm - 20.00 mm)

Boring Range	Boring Bar				Weight	Insert Form	Part No.	Insert Form	Part No.
	A	D <sub>1</sub>	X <sub>1</sub>	X <sub>3 min</sub>					
0.236 - 0.315	0.197*	0.492 - 0.984	0.984	2.756	0.022 (lbs)	211**	514032	-	-
0.315 - 0.394	0.276*	0.689 - 1.378	0.984	3.189	0.044 (lbs)	211**	514033	-	-
0.394 - 0.472	0.315*	0.787 - 1.575	0.984	3.346	0.066 (lbs)	101	514003	20**	514004
0.472 - 0.551	0.394*	0.984 - 1.969	0.984	3.937	0.110 (lbs)	101	514005	20**	514006
0.551 - 0.630	0.472*	1.181 - 2.362	1.181	4.488	0.198 (lbs)	101	514007	20**	514008
0.630 - 0.709	0.551*	2.205 - 2.756	1.181	4.764	0.287 (lbs)	101	514009	20**	514010
0.709 - 0.787	0.551*	2.205 - 2.756	1.181	4.764	0.287 (lbs)	101	514011	20**	514012
6.00 - 8.00	5.00*	12.50 - 25.00	25.00	70.00	0.01 (kg)	211**	514032	-	-
8.00 - 10.00	7.00*	17.50 - 35.00	25.00	81.00	0.02 (kg)	211**	514033	-	-
10.00 - 12.00	8.00*	20.00 - 40.00	25.00	85.00	0.03 (kg)	101	514003	20**	514004
12.00 - 14.00	10.00*	25.00 - 50.00	25.00	100.00	0.05 (kg)	101	514005	20**	514006
14.00 - 16.00	12.00*	30.00 - 60.00	30.00	114.00	0.09 (kg)	101	514007	20**	514008
16.00 - 18.00	14.00*	56.00 - 70.00	30.00	121.00	0.13 (kg)	101	514009	20**	514010
18.00 - 20.00	14.00*	56.00 - 70.00	30.00	121.00	0.13 (kg)	101	514011	20**	514012

\*Fixture-through reducing sleeve required (B10-A: 17)

\*\*Not suitable for indexable inserts with a radius of 0.031" (0.8 mm)

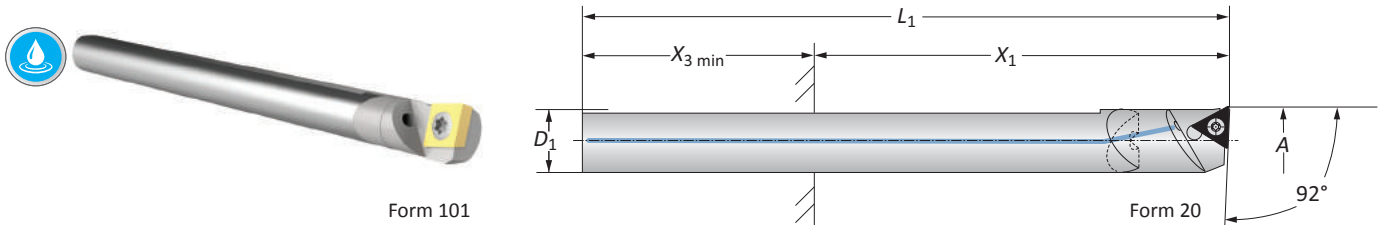

Carbide Boring Bars | Diameter Range: 0.236" - 0.787" (6.00 mm - 20.00 mm)

Boring Range	Boring Bar				Weight	Insert Form	Part No.	Insert Form	Part No.
	A	D <sub>1</sub>	X <sub>1</sub>	X <sub>3 min</sub>					
0.236 - 0.315	0.197*	0.492 - 1.575	0.984	3.543	0.044 (lbs)	211**	514034	-	-
0.315 - 0.394	0.276*	0.827 - 2.205	0.984	4.291	0.110 (lbs)	211**	514035	-	-
0.394 - 0.472	0.315*	0.866 - 2.520	0.984	4.606	0.154 (lbs)	101	514015	20**	514016
0.472 - 0.551	0.394*	2.008 - 3.150	0.984	5.512	0.287 (lbs)	101	514017	20**	514018
0.551 - 0.630	0.472*	2.677 - 3.780	1.181	6.378	0.485 (lbs)	101	514019	20**	514020
0.630 - 0.709	0.551*	3.031 - 4.409	1.181	5.591	0.573 (lbs)	101	514021	20**	514022
0.630 - 0.709	0.551*	4.409 - 5.787	1.181	6.969	0.728 (lbs)	101	514023	20**	514024
0.709 - 0.787	0.551*	3.031 - 4.409	1.181	5.591	0.573 (lbs)	101	514025	20**	514026
0.709 - 0.787	0.551*	4.409 - 5.787	1.181	6.969	0.728 (lbs)	101	514027	20**	514028
6.00 - 8.00	5.00*	12.50 - 40.00	25.00	90.00	0.02 (kg)	211**	514034	-	-
8.00 - 10.00	7.00*	21.00 - 56.00	25.00	109.00	0.05 (kg)	211**	514035	-	-
10.00 - 12.00	8.00*	22.00 - 64.00	25.00	117.00	0.07 (kg)	101	514015	20**	514016
12.00 - 14.00	10.00*	51.00 - 80.00	25.00	140.00	0.13 (kg)	101	514017	20**	514018
14.00 - 16.00	12.00*	68.00 - 96.00	30.00	162.00	0.22 (kg)	101	514019	20**	514020
16.00 - 18.00	14.00*	77.00 - 112.00	30.00	142.00	0.26 (kg)	101	514021	20**	514022
16.00 - 18.00	14.00*	112.00 - 147.00	30.00	177.00	0.33 (kg)	101	514023	20**	514024
18.00 - 20.00	14.00*	77.00 - 112.00	30.00	142.00	0.26 (kg)	101	514025	20**	514026
18.00 - 20.00	14.00*	112.00 - 147.00	30.00	177.00	0.33 (kg)	101	514027	20**	514028

\*Fixture-through reducing sleeve required (B10-A: 17)

\*\*Not suitable for indexable inserts with a radius of 0.031" (0.8 mm)

INDEX



## Serrated Tool Bodies | Insert Holders

Diameter Range: 0.787" - 1.260" (20.00 mm - 32.00 mm)

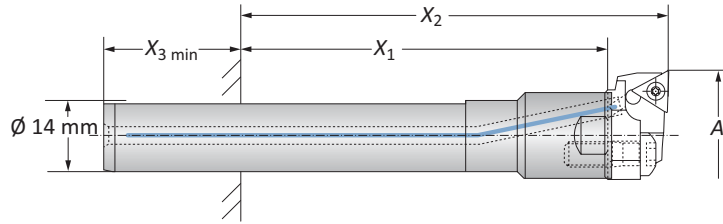

### Serrated Tool Bodies

	Substrate	Boring Range	Serrated Tool Body*			Weight	Part No.
		A	X <sub>1</sub>	X <sub>2</sub>	X <sub>3 min</sub>		
<b>i</b>	Steel	0.787 - 1.260	1.457 - 2.835	1.929 - 3.307	1.181	0.287 (lbs)	<b>514029</b>
	Carbide	0.787 - 1.260	2.550 - 3.937	3.031 - 4.409	1.181	0.551 (lbs)	<b>514030</b>
	Carbide	0.787 - 1.260	3.937 - 5.315	4.409 - 5.787	1.181	0.728 (lbs)	<b>514031</b>
<b>m</b>	Steel	20.00 - 32.00	37.00 - 72.00	49.00 - 84.00	30.00	0.13 (kg)	<b>514029</b>
	Carbide	20.00 - 32.00	65.00 - 100.00	77.00 - 112.00	30.00	0.25 (kg)	<b>514030</b>
	Carbide	20.00 - 32.00	100.00 - 135.00	112.00 - 147.00	30.00	0.33 (kg)	<b>514031</b>

\*Fixture-through reducing sleeve (B10-A: 17)



Form 101

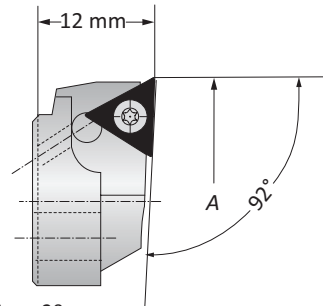

Form 20

### Insert Holders

	Boring Range		Insert Form	Part No.	Insert Form	Part No.
	A	Weight				
<b>i</b>	0.787 - 0.866	0.022 (lbs)	101	<b>502052</b>	20	<b>502046*</b>
	0.866 - 0.945	0.022 (lbs)	101	<b>502053</b>	20	<b>502047*</b>
	0.945 - 1.024	0.022 (lbs)	101	<b>502054</b>	20	<b>502048*</b>
	1.024 - 1.102	0.022 (lbs)	101	<b>502055</b>	20	<b>502049*</b>
	1.102 - 1.181	0.022 (lbs)	101	<b>502056</b>	20	<b>502050*</b>
	1.181 - 1.260	0.022 (lbs)	101	<b>502057</b>	20	<b>502051*</b>
<b>m</b>	20.00 - 22.00	0.01 (kg)	101	<b>502052</b>	20	<b>502046*</b>
	22.00 - 24.00	0.01 (kg)	101	<b>502053</b>	20	<b>502047*</b>
	24.00 - 26.00	0.01 (kg)	101	<b>502054</b>	20	<b>502048*</b>
	26.00 - 28.00	0.01 (kg)	101	<b>502055</b>	20	<b>502049*</b>
	28.00 - 30.00	0.01 (kg)	101	<b>502056</b>	20	<b>502050*</b>
	30.00 - 32.00	0.01 (kg)	101	<b>502057</b>	20	<b>502051**</b>

\*Not suitable for indexable inserts with a radius of 0.031" (0.80 mm)

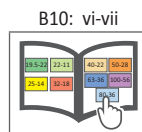
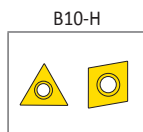
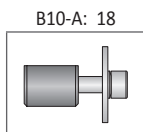
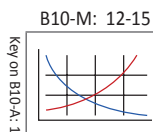

**i** = Imperial (in)  
**m** = Metric (mm)  
 Inserts sold separately

A  
B  
C  
D  
E  
F  
G  
H  
I  
J  
K  
L  
M  
INDEX

## Serrated Tool Bodies | Insert Holders

Diameter Range: 1.142" - 2.087" (29.00 mm - 53.00 mm)

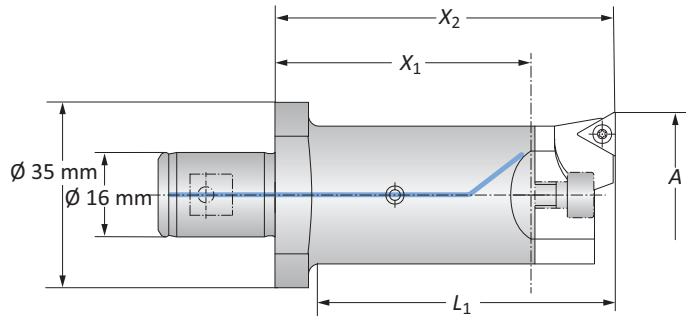

### Serrated Tool Bodies

	Boring Range		Serrated Tool Body			Weight	Part No.
	A	X <sub>1</sub>	X <sub>2</sub>	L <sub>1</sub>			
i	1.142 - 2.087	1.890	2.520	2.205	0.441 (lbs)	236021	
	1.142 - 2.087	3.307	3.937	3.622	0.661 (lbs)		
m	29.00 - 53.00	48.00	64.00	56.00	0.20 (kg)	236021	
	29.00 - 53.00	84.00	100.00	92.00	0.30 (kg)		

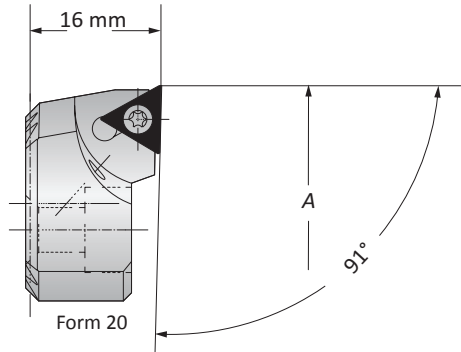
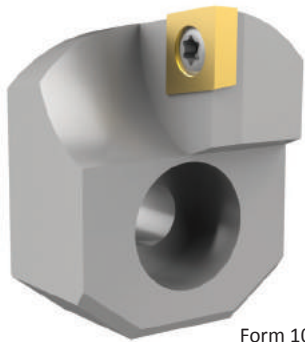

### Insert Holders

	Boring Range		Weight	Insert Form	Part No.	
	A					
i	1.142 - 1.614	0.088 (lbs)	101	236023		
	1.142 - 1.614	0.088 (lbs)			20*	236022
	1.575 - 2.087	0.132 (lbs)			101	236025
	1.575 - 2.087	0.132 (lbs)			20*	236024
m	29.00 - 41.00	0.04 (kg)	101	236023		
	29.00 - 41.00	0.04 (kg)			20*	236022
	40.00 - 53.00	0.06 (kg)			101	236025
	40.00 - 53.00	0.06 (kg)			20*	236024

\*Not suitable for indexable inserts with a radius of 0.031" (0.80 mm)

B10-M: 12-15

Key on B10-A: 1

B10-A: 18

B10-H

B10: vi-vii

i = Imperial (in)  
m = Metric (mm)  
Inserts sold separately

## Alu-Line Serrated Slides | Insert Holders

Diameter Range: 2.677" - 5.984" (68.00 mm - 152.00 mm)

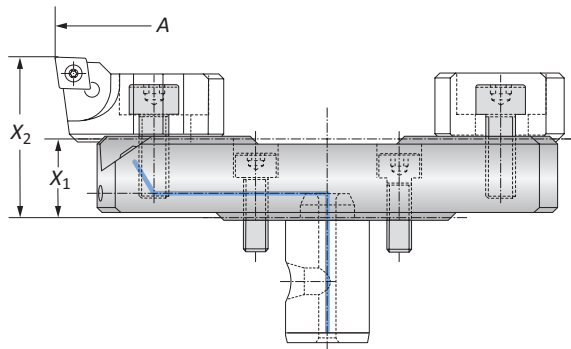

### Alu-Line Serrated Slides

	Boring Range		Serrated Slide		Weight	Part No.
	A	X <sub>1</sub>	X <sub>2</sub>			
<b>i</b>	2.677 - 3.780	0.630	1.279		0.220 (lbs)	<b>501054</b>
	3.780 - 4.882	0.630	1.279		0.220 (lbs)	<b>501055</b>
	4.882 - 5.984	0.630	1.279		0.440 (lbs)	<b>501056</b>
<b>m</b>	68.00 - 96.00	16.00	32.50		0.10 (kg)	<b>501054</b>
	96.00 - 124.00	16.00	32.50		0.10 (kg)	<b>501055</b>
	124.00 - 152.00	16.00	32.50		0.20 (kg)	<b>501056</b>

### Insert Holders

	Boring Range		Insert Form	Part No.
	A	Weight		
<b>i</b>	2.677 - 5.984	0.110 (lbs)	101	<b>502064</b>
	2.677 - 5.984	0.110 (lbs)	20	<b>502069</b>
<b>m</b>	68.00 - 152.00	0.05 (kg)	101	<b>502064</b>
	68.00 - 152.00	0.05 (kg)	20	<b>502069</b>



Form 20

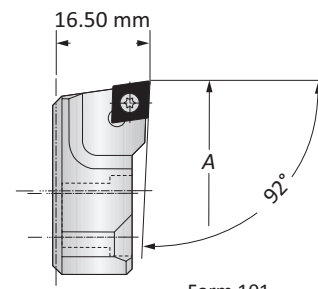

Form 101

### Counterweights

	Counterweight		Part No.
	X <sub>1</sub>	Weight	
<b>i</b>	0.528	0.110 (lbs)	<b>502165</b>
<b>m</b>	13.40	0.05 (kg)	<b>502165</b>

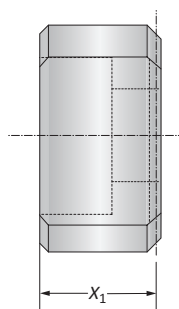

### Alu-Line Coolant Delivery Sections

	Coolant Delivery		Part No.
	X <sub>1</sub>	Weight	
<b>i</b>	1.004	0.022 (lbs)	<b>450137</b>
<b>m</b>	25.50	0.01 (kg)	<b>450137</b>

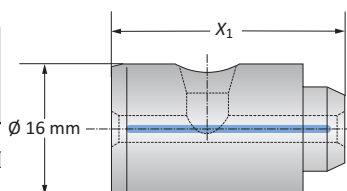

B10-M: 12-15

B10-A: 18

B10-H

B10: vi-vii

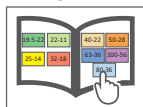
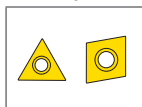
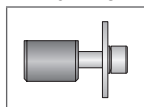
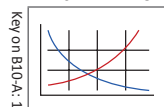

**i** = Imperial (in)  
**m** = Metric (mm)  
 Inserts sold separately

A  
B  
C  
D  
E  
F  
G  
H  
I  
J  
K  
L  
M  
INDEX

## Insert Holders for Boring Heads

Diameter Range: 2.047" - 4.016" (52.00 mm - 102.00 mm)



Form 101

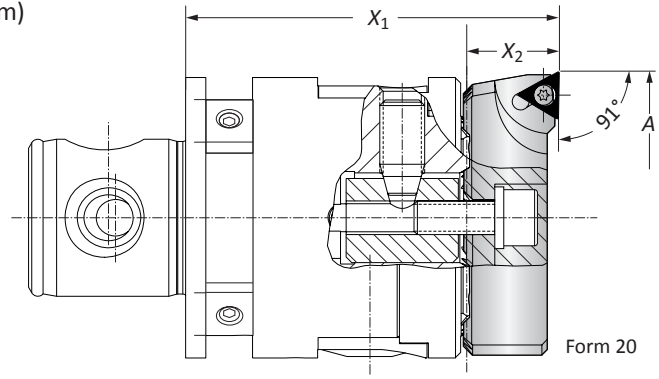

### Insert Holders for Boring Heads

	Boring Range	Insert Holder		Weight	Insert Form	Part No.
		A	X <sub>1</sub>			
<b>i</b>	2.047 - 3.031	2.598	0.650	0.132 (lbs)	101	<b>236027</b>
	2.047 - 3.031	2.598	0.650	0.132 (lbs)	20	<b>236026</b>
	2.992 - 4.016	2.598	0.650	0.220 (lbs)	101	<b>236029</b>
	2.992 - 4.016	2.598	0.650	0.220 (lbs)	20	<b>236028</b>
<b>m</b>	52.00 - 77.00	66.00	16.50	0.06 (kg)	101	<b>236027</b>
	52.00 - 77.00	66.00	16.50	0.06 (kg)	20	<b>236026</b>
	76.00 - 102.00	66.00	16.50	0.10 (kg)	101	<b>236029</b>
	76.00 - 102.00	66.00	16.50	0.10 (kg)	20	<b>236028</b>

### Clamping Piece for Insert Holder for Boring Heads

	Boring Range	Service Key	Complete Part No.
<b>m</b>	52.00 - 102.00	s5	<b>236020</b>

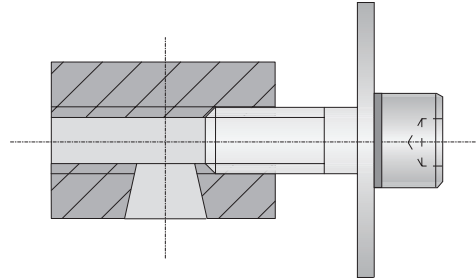

B10-M: 12-15

B10-A: 18

B10-H

B10: vi-vii

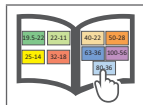
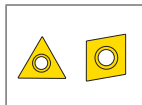
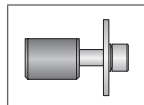
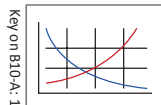

Key on B10-A: 1

**i** = Imperial (in)  
**m** = Metric (mm)

Inserts sold separately

## Outside Turning Insert Holders for Boring Heads

Outside Turning | Diameter Range: 0.157" - 2.598" (4.00 mm - 66.00 mm)

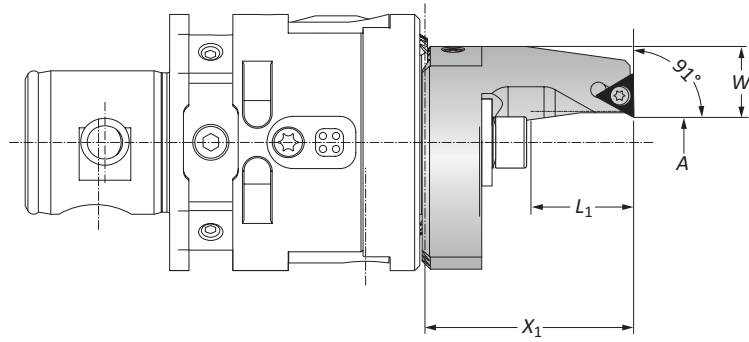

### Type A Insert Holders

	Boring Range		Insert Holder			Weight	Type	Insert Form	Part No.
	A	X <sub>1</sub>	L <sub>1</sub>	W					
i	0.157 - 0.689	1.594	0.787	0.653	0.220	A	20*	236081	
	0.650 - 1.181	1.988	1.181	0.437	0.220	A	20*	236082	
m	4.00 - 17.50	40.50	20.00	16.60	0.10	A	20*	236081	
	16.50 - 30.00	50.50	30.00	11.10	0.10	A	20*	236082	

**NOTE:** Clockwise and neutral execution

\*Not suitable for indexable inserts with a radius of 0.031" (0.80 mm)

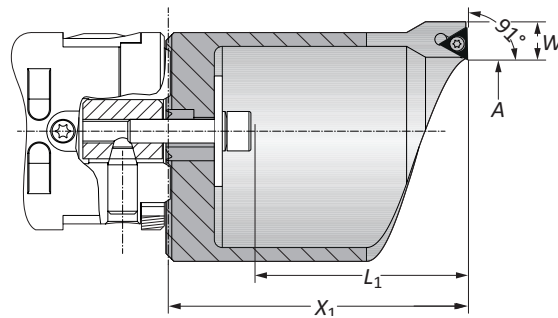

### Type B Insert Holders

	Boring Range		Insert Holder			Weight	Type	Insert Form	Part No.
	A	X <sub>1</sub>	L <sub>1</sub>	W					
i	1.142 - 1.732	2.952	2.126	0.377	0.661 (lbs)	B	20*	236083	
	1.693 - 2.598	3.956	3.110	0.377	0.882 (lbs)	B	20*	236084	
m	29.00 - 44.00	75.50	54.00	9.60	0.30 (kg)	B	20*	236083	
	43.00 - 66.00	100.50	79.00	9.60	0.40 (kg)	B	20*	236084	

**NOTE:** Clockwise and neutral execution

\*Not suitable for indexable inserts with a radius of 0.031" (0.80 mm)

### Clamping Pieces for Outside Turning Insert Holders

	Insert Holder Type	Boring Range	Service Key	Complete Part No.
m	A	4.00 - 30.00	s5	236088
	B	29.00 - 66.00	s5	236089

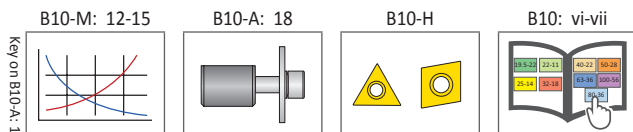
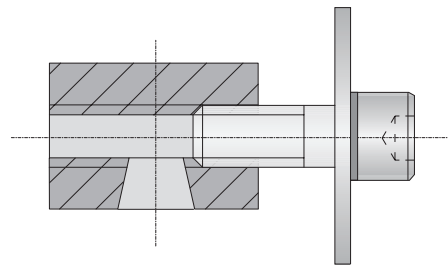

i = Imperial (in)  
m = Metric (mm)  
Inserts sold separately

A  
B  
C  
D  
E  
F  
G  
H  
I  
J  
K  
L  
M  
INDEX



## Outside Turning Serrated Slides | Insert Holders

Diameter Range: 0.079" - 2.283" (2.00 mm - 58.00 mm)

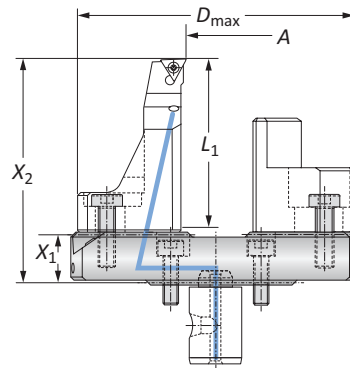

### Serrated Slides

	Outside Turning Range		Serrated Slide			Interfering Diameter	Part No.
	A	X <sub>1</sub>	X <sub>2</sub>	L <sub>1</sub>	Weight	D <sub>max</sub>	
i	0.079 - 1.181	0.630	2.874	2.165	0.771 (lbs)	3.976	501064
	1.181 - 2.283	0.630	2.874	2.165	0.970 (lbs)	5.079	501065
m	2.00 - 30.00	16.00	73.00	55.00	0.35 (kg)	101.00	501064
	30.00 - 58.00	16.00	73.00	55.00	0.44 (kg)	129.00	501065



### Insert Holders

	Boring Range	Insert Holder	Weight	Insert Form	Part No.
	A	X <sub>1</sub>			
i	0.079 - 2.283	2.244	0.331 (lbs)	20*	502082
m	2.00 - 58.00	57.00	0.15 (kg)	20*	502082

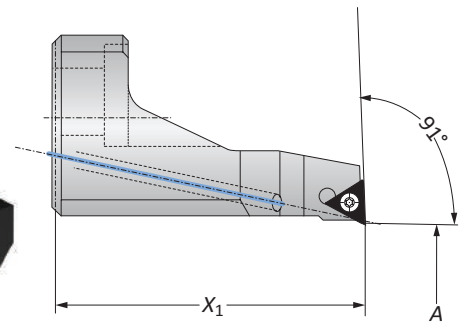

\*Clockwise and neutral execution

### Counterweights

	Counterweight		Part No.
	X <sub>1</sub>	Weight	
i	1.486	0.352 (lbs)	502183
m	37.75	0.16 (kg)	502183

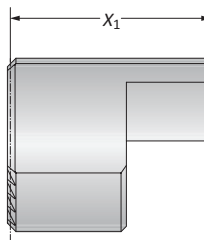

### Alu-Line Coolant Delivery Sections

	Coolant Delivery Section		Part No.
	X <sub>1</sub>	Weight	
i	1.004	0.022 (lbs)	450137
m	25.50	0.01 (kg)	450137

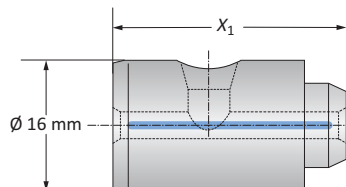

B10-M: 12-15

B10-A: 18

B10-H

B10: vi-vii

Key on B10-A: 1

i = Imperial (in)  
m = Metric (mm)

Inserts sold separately

Accessories

Imperial Reducing Sleeves | Metric Reducing Sleeves

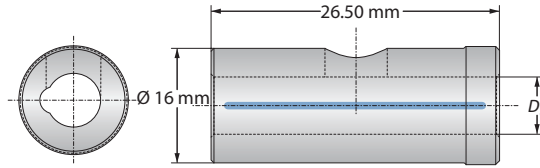

Reducing Sleeve

Reducing Sleeve		Weight	Part No.
	$D_3$		
m	4.00	0.05 (kg)	450129
	5.00	0.04 (kg)	450130
	7.00	0.04 (kg)	450132
	8.00	0.04 (kg)	450133
	10.00	0.03 (kg)	450134
	12.00	0.02 (kg)	450135
	14.00	0.01 (kg)	450136

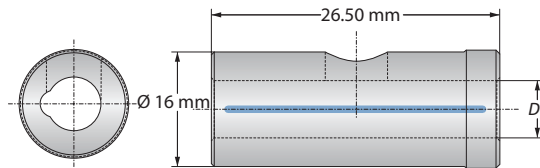

Imperial Reducing Sleeves

Imperial Reducing Sleeves		Weight	Part No.
	$D_3$		
i	0.125	0.110 (lbs)	450142
	0.250	0.088 (lbs)	450143
	0.312	0.088 (lbs)	450144
	0.375	0.088 (lbs)	450145
	0.500	0.088 (lbs)	450146

i = Imperial (in)  
m = Metric (mm)

A  
B  
C  
D  
E  
F  
G  
H  
I  
J  
K  
L  
M  
INDEX

## Accessories

Clamping Elements | Thread Pin | Balancing Element | 3E<sup>TECH+</sup> Charging Unit

### Clamping Elements for Insert Holders

Boring Range	1 Cap Screw	Hex Size	2 Washer	3 Clamping Nut	4 Locking Washer	Complete Part No.
4 - 30	070153	s5	315155	236120	215254	236088
29 - 66	070153	s5	315156	236120	215254	236089
52 - 102	115147	s5	115725	236120	-	236020

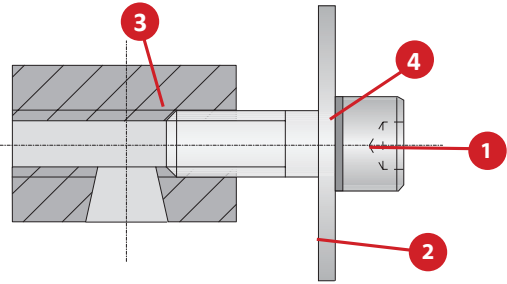

### Clamping Elements for Serrated Tool Body

1 Cap Screw	Hex Size	2 Clamping Piece
027154	s4	145184

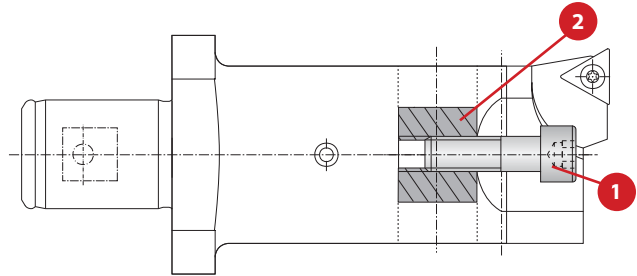

### Thread Pin

Service Key	1 Part No.
S3 / A	415244

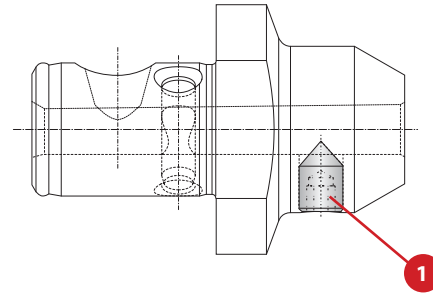

### Balancing Element with Screw

Nominal Size	Key Size / Type	1 Part No.
M8 x 1.25 x 8	s2 / A	536005

NOTE: Balancing elements sold separately

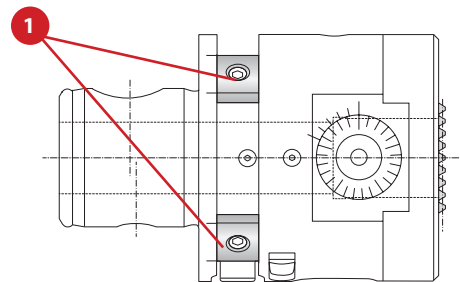

### 3E<sup>TECH+</sup> Accessories

1 Charging Unit
Part No.
536016

NOTE: Charging unit sold separately from 3E<sup>TECH+</sup>



NOTE: 3E<sup>TECH+</sup> adjustment accuracy of 0.0001" or 0.001 mm on diameter

### 3E<sup>TECH</sup> (Old Display) Accessories

1 Sealing Ring	2 Battery CR2032
Part No.	Part No.
215483	515491

NOTE: Not required for 3E<sup>TECH+</sup> (new display)

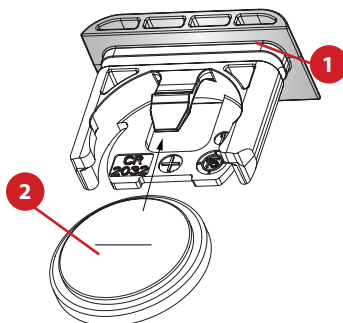

Accessories

No.	Part	Insert Form	Size	Part No.
1	Clamping screw	-	-	070333
2	Thread pin for tool clamping	-	-	215674
3	Clamping screw for balance weight	-	-	115470
4	Balancing screw plug	-	-	115119
5	Insert screws	Form 20 Form 101 Form 211	T7 T8 T6	115535 115676 215377
6	Hex wrench	-	s2.5 s2	115575 215473
7	Hex wrench	-	s4	115576
8	Torx driver	-	T6 T7 T8	115537 115591 115590
9	Torx screwdriver	Form 211 Form 20 Form 101	T6 T7 T8	415507 415508 415514

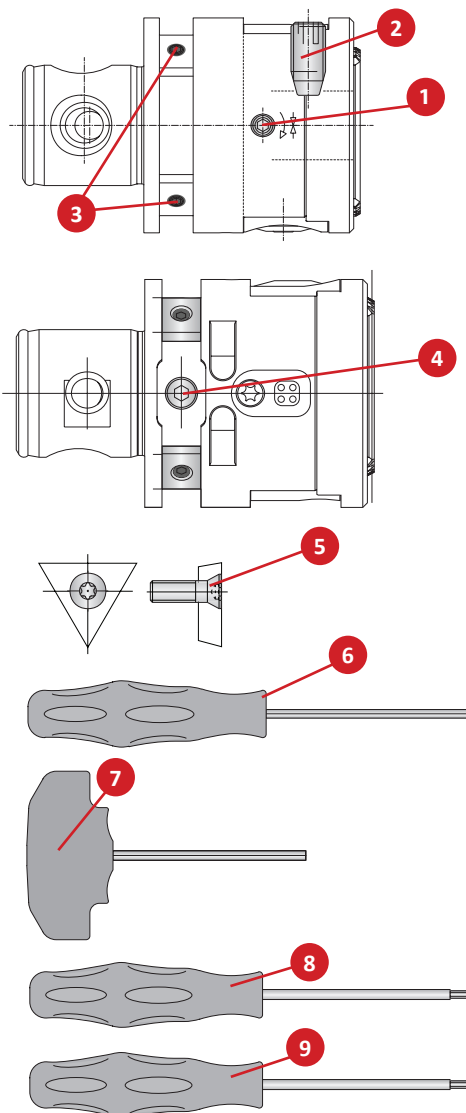

No.	Part	Size	Part No.
1	Screw for securing insert holder	T25	415112
2	Clamping piece	-	145184
3	Cap screw for securing insert holders	s4	027154
4	Cap screw for securing insert holder/counterweight	s4	315248
5	Set screw - coolant	s1.5	114224
6	Cap screw for securing serrated slide	s3	116289
8	Sealing ring for coolant delivery	-	415386

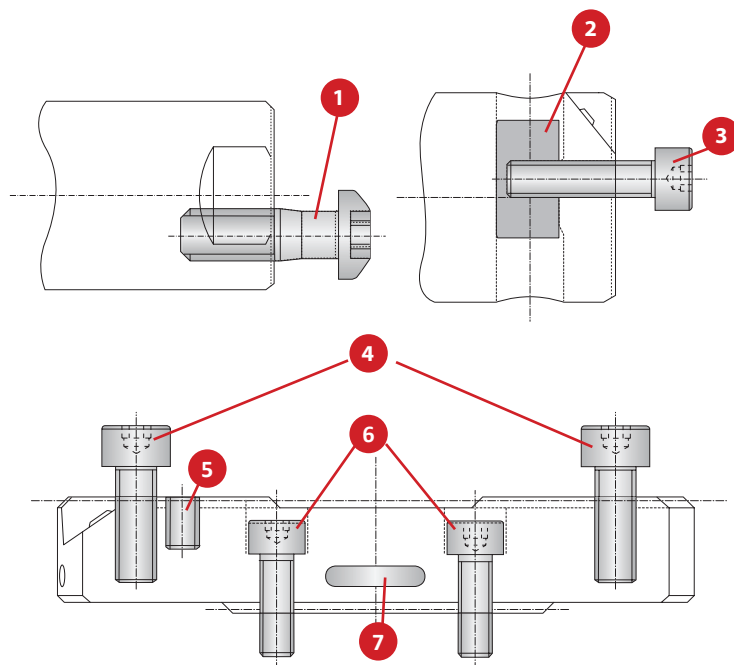

A  
B  
C  
D  
E  
F  
G  
H  
I  
J  
K  
L  
M  
INDEX

## Kit Components

3E<sup>TECH+</sup> | Insert Form 101 | Diameter Range: 0.393" - 1.181" (10.00 mm - 30.00 mm)

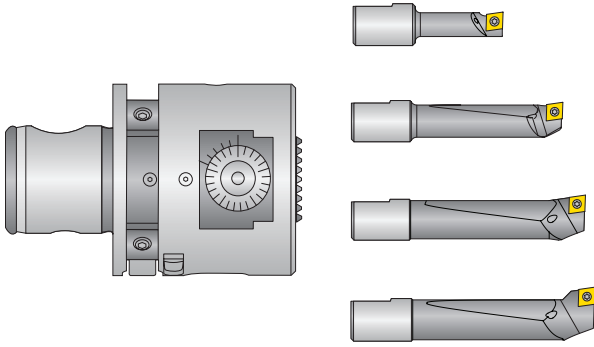

Diameter Range: 0.393" - 1.181" (10.00 mm - 30.00 mm)

Kit Components					
	Boring Head	Boring Bar Range	Boring Bars	Service Keys	Kit No.
i	563002	0.393 - 0.590	218048	115575 (s2.5)	104046
		0.590 - 0.787	081041	215403 (s4)	
		0.787 - 0.984	081042	115590 (T8)	
		0.984 - 1.181	081043		
m	536002	10.00 - 15.00	218048	115575 (s2.5)	103046
		15.00 - 20.00	081041	215403 (s4)	
		20.00 - 25.00	081042	115590 (T8)	
		25.00 - 30.00	081043		

NOTE: Balancing elements and inserts sold separately

NOTE: 3E<sup>TECH+</sup> digital readout module and charging station sold separately



### 3E<sup>TECH+</sup> Digital Readout Module

Part No.	Charging Unit*
536015	536016

NOTE: WEEE-Reg.-Nr. DE 15820388

\*Charging unit sold separately



NOTE: 3E<sup>TECH+</sup> adjustment accuracy of 0.0001" or 0.001 mm on diameter

B10-M: 12-15 	B10-A: 18 	B10-H 	B10: vi-vii 
------------------	---------------	-----------	-----------------

Key on B10-A: 1

i = Imperial (in)  
m = Metric (mm)

Inserts sold separately

**IMPORTANT:** Max spindle speed refers to maximum possible speed for an individual boring head and is not a recommended parameter. Refer to page B10-M: 12 for recommended application-specific parameters. Factory technical assistance is available for your specific applications through our Application Engineering department.  
ext: 7611 | email: [appeng@alliedmachine.com](mailto:appeng@alliedmachine.com)



## Kit Components

3E<sup>TECH+</sup> | Insert Form 20 | Diameter Range: 0.393" - 1.181" (10.00 mm - 30.00 mm)

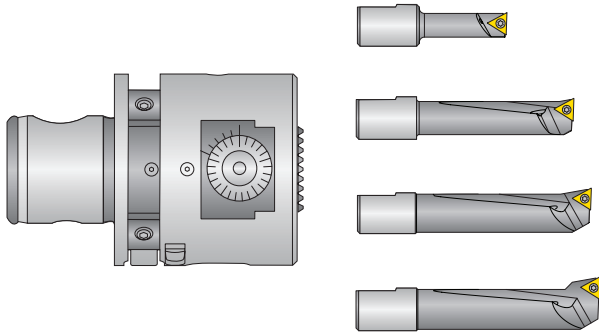

Diameter Range: 0.393" - 1.181" (10.00 mm - 30.00 mm)

Kit Components					
	Boring Head	Boring Bar Range	Boring Bars	Service Keys	Kit No.
<b>i</b>	563002	0.393 - 0.590	218059	115575 (s2.5)	<b>104045</b>
		0.590 - 0.787	081045	215403 (s4)	
		0.787 - 0.984	081046	115591 (T7)	
		0.984 - 1.181	081047		
<b>m</b>	536002	10.00 - 15.00	218059	115575 (s2.5)	<b>103045</b>
		15.00 - 20.00	081045	215403 (s4)	
		20.00 - 25.00	081046	115591 (T7)	
		25.00 - 30.00	081047		

NOTE: Balancing elements and inserts sold separately

NOTE: 3E<sup>TECH+</sup> digital readout module and charging station sold separately



### 3E<sup>TECH+</sup> Digital Readout Module

Part No.	Charging Unit*
536015	536016

NOTE: WEEE-Reg.-Nr. DE 15820388

\*Charging unit sold separately



NOTE: 3E<sup>TECH+</sup> adjustment accuracy of 0.0001" or 0.001 mm on diameter

B10-M: 12-15

B10-A: 18

B10-H

B10: vi-vii

Key on B10-A-1

**i** = Imperial (in)  
**m** = Metric (mm)

Inserts sold separately

**IMPORTANT:** Max spindle speed refers to maximum possible speed for an individual boring head and is not a recommended parameter. Refer to page B10-M: 12 for recommended application-specific parameters. Factory technical assistance is available for your specific applications through our Application Engineering department.  
ext: 7611 | email: [appeng@alliedmachine.com](mailto:appeng@alliedmachine.com)

A  
B  
C  
D  
E  
F  
G  
H  
I  
J  
K  
L  
M  
INDEX

## Kit Components

3E<sup>TECH+</sup> | Insert Form 101 | Diameter Range: 0.393" - 4.016" (10.00 mm - 102.00 mm)

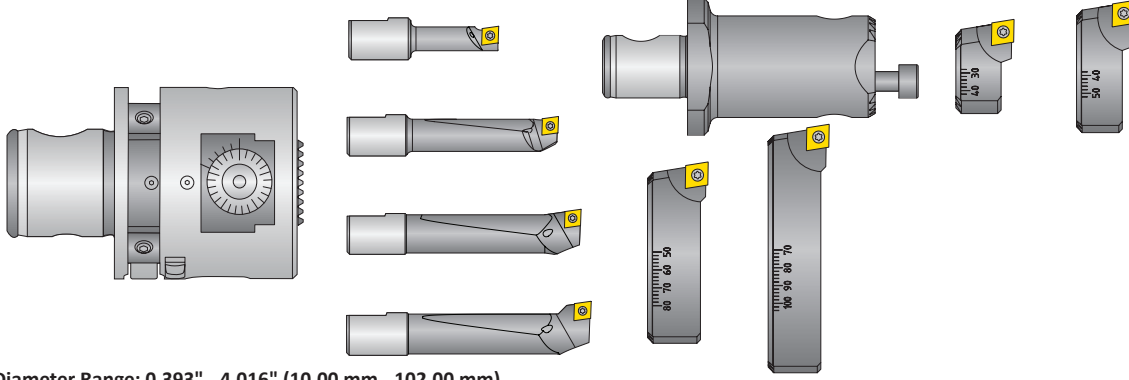

Diameter Range: 0.393" - 4.016" (10.00 mm - 102.00 mm)

Kit Components										
Boring Head	Boring Bars		Serrated Tool Body and Insert Holders			Insert Holders for Boring Head			Service Keys	Kit No.
	Boring Bar Range	Part No.	Serrated Tool Body	Insert Holder Range	Part No.	Insert Holder Range	Part No.	Clamping Piece		
i	0.393 - 0.590	218048	236021	1.142 - 1.614	236023	2.047 - 3.031	236027	236020	115575 (s2.5)	104048
	0.590 - 0.787	081041		1.575 - 2.087	236025	2.992 - 4.016	236029		215403 (s4)	
	0.787 - 0.984	081042							215521 (s5)	
	0.984 - 1.181	081043							115590 (T8)	
m	10.00 - 15.00	218048	236021	29.00 - 41.00	236023	52.00 - 77.00	236027	236020	115575 (s2.5)	103048
	15.00 - 20.00	081041		40.00 - 53.00	236025	76.00 - 102.00	236029		215403 (s4)	
	20.00 - 25.00	081042							215521 (s5)	
	25.00 - 30.00	081043							115590 (T8)	

NOTE: Balancing elements and inserts sold separately

NOTE: 3E<sup>TECH+</sup> digital readout module and charging station sold separately



### 3E<sup>TECH+</sup> Digital Readout Module

Part No.	Charging Unit*
536015	536016

NOTE: WEEE-Reg.-Nr. DE 15820388

\*Charging unit sold separately



NOTE: 3E<sup>TECH+</sup> adjustment accuracy of 0.0001" or 0.001 mm on diameter

Key on B10-A: 1

B10-M: 12-15	B10-A: 18	B10-H	B10: vi-vii

i = Imperial (in)  
m = Metric (mm)

Inserts sold separately

**IMPORTANT:** Max spindle speed refers to maximum possible speed for an individual boring head and is not a recommended parameter. Refer to page B10-M: 12 for recommended application-specific parameters. Factory technical assistance is available for your specific applications through our Application Engineering department.  
ext: 7611 | email: [appeng@alliedmachine.com](mailto:appeng@alliedmachine.com)

## Kit Components

3E<sup>TECH+</sup> | Insert Form 20 | Diameter Range: 0.393" - 4.016" (10.00 mm - 102.00 mm)

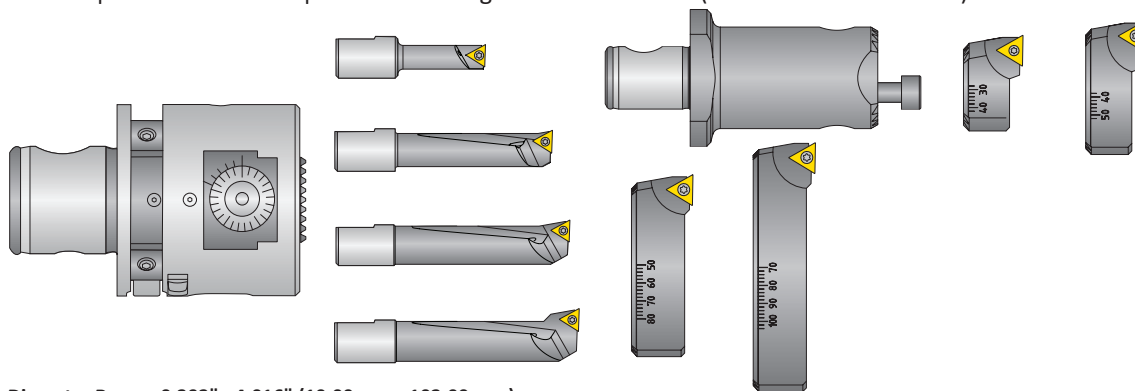

Diameter Range: 0.393" - 4.016" (10.00 mm - 102.00 mm)

Kit Components										
Boring Head	Boring Bars		Serrated Tool Body and Insert Holders			Insert Holders for Boring Head			Service Keys	Kit No.
	Boring Bar Range	Part No.	Serrated Tool Body	Insert Holder Range	Part No.	Insert Holder Range	Part No.	Clamping Piece		
i	0.393 - 0.590	218059	236021	1.142 - 1.614	236026	2.047 - 3.031	236022	236020	115575 (s2.5)	104047
	0.590 - 0.787	081045		1.575 - 2.087	236028	2.992 - 4.016	236024		215403 (s4)	
	0.787 - 0.984	081046							215521 (s5)	
	0.984 - 1.181	081047							115591 (T7)	
m	10.00 - 15.00	218059	236021	29.00 - 41.00	236026	52.00 - 77.00	236022	236020	115575 (s2.5)	103047
	15.00 - 20.00	081045		40.00 - 53.00	236028	76.00 - 102.00	236024		215403 (s4)	
	20.00 - 25.00	081046							215521 (s5)	
	25.00 - 30.00	081047							115591 (T7)	

NOTE: Balancing elements and inserts sold separately

NOTE: 3E<sup>TECH+</sup> digital readout module and charging station sold separately



### 3E<sup>TECH+</sup> Digital Readout Module

Part No.	Charging Unit*
536015	536016

NOTE: WEEE-Reg.-Nr. DE 15820388

\*Charging unit sold separately



NOTE: 3E<sup>TECH+</sup> adjustment accuracy of 0.0001" or 0.001 mm on diameter

B10-M: 12-15

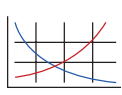

B10-A: 18

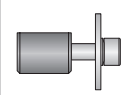

B10-H

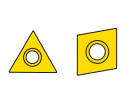

B10: vi-vii



i = Imperial (in)  
m = Metric (mm)

Inserts sold separately

**IMPORTANT:** Max spindle speed refers to maximum possible speed for an individual boring head and is not a recommended parameter. Refer to page B10-M: 12 for recommended application-specific parameters. Factory technical assistance is available for your specific applications through our Application Engineering department.  
ext: 7611 | email: [appeng@alliedmachine.com](mailto:appeng@alliedmachine.com)

## Kit Components

Nondigital | Insert Form 101 | Diameter Range: 0.393" - 1.181" (10.00 mm - 30.00 mm)

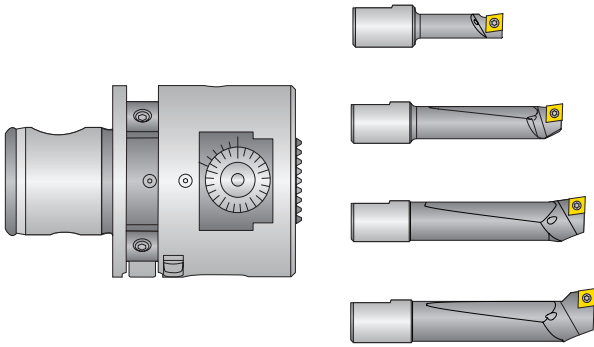

Diameter Range: 0.393" - 1.181" (10.00 mm - 30.00 mm)

Kit Components					
	Boring Head	Boring Bar Range	Boring Bars	Service Keys	Kit No.
i	563001	0.393 - 0.590	218048	115575 (s2.5)	104050
		0.590 - 0.787	081041	215403 (s4)	
		0.787 - 0.984	081042	115590 (T8)	
		0.984 - 1.181	081043		
m	536001	10.00 - 15.00	218048	115575 (s2.5)	103050
		15.00 - 20.00	081041	215403 (s4)	
		20.00 - 25.00	081042	115590 (T8)	
		25.00 - 30.00	081043		

NOTE: Balancing elements and inserts sold separately



B10-M: 12-15 B10-A: 18 B10-H B10: vi-vii

key on B10-A: 1

i = Imperial (in)  
m = Metric (mm)

Inserts sold separately

**IMPORTANT:** Max spindle speed refers to maximum possible speed for an individual boring head and is not a recommended parameter. Refer to page B10-M: 12 for recommended application-specific parameters. Factory technical assistance is available for your specific applications through our Application Engineering department.  
ext: 7611 | email: [appeng@alliedmachine.com](mailto:appeng@alliedmachine.com)



## Kit Components

Nondigital | Insert Form 20 | Diameter Range: 0.393" - 1.181" (10.00 mm - 30.00 mm)

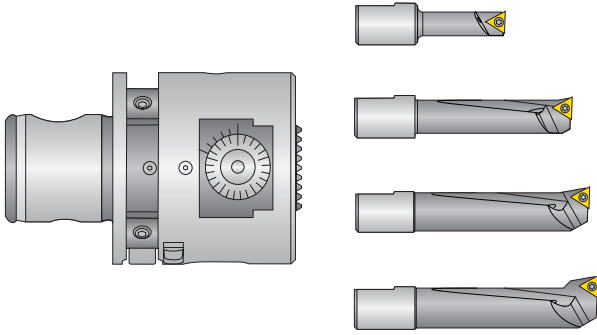

Diameter Range: 0.393" - 1.181" (10.00 mm - 30.00 mm)

Kit Components					
	Boring Head	Boring Bar Range	Boring Bars	Service Keys	Kit No.
i	563001	0.393 - 0.590	218059	115575 (s2.5)	104049
		0.590 - 0.787	081045	215403 (s4)	
		0.787 - 0.984	081046	115591 (T7)	
		0.984 - 1.181	081047		
m	536001	10.00 - 15.00	218059	115575 (s2.5)	103049
		15.00 - 20.00	081045	215403 (s4)	
		20.00 - 25.00	081046	115591 (T7)	
		25.00 - 30.00	081047		

NOTE: Balancing elements and inserts sold separately



Key on B10-A: 1

B10-M: 12-15

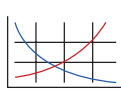

B10-A: 18

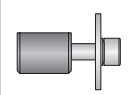

B10-H

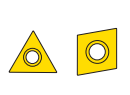

B10: vi-vii



i = Imperial (in)  
 m = Metric (mm)  
 Inserts sold separately

**IMPORTANT:** Max spindle speed refers to maximum possible speed for an individual boring head and is not a recommended parameter. Refer to page B10-M: 12 for recommended application-specific parameters. Factory technical assistance is available for your specific applications through our Application Engineering department.  
 ext: 7611 | email: [appeng@alliedmachine.com](mailto:appeng@alliedmachine.com)

A  
B  
C  
D  
E  
F  
G  
H  
I  
J  
K  
L  
M  
INDEX

## Kit Components

Nondigital | Insert Form 101 | Diameter Range: 0.393" - 4.016" (10.00 mm - 102.00 mm)

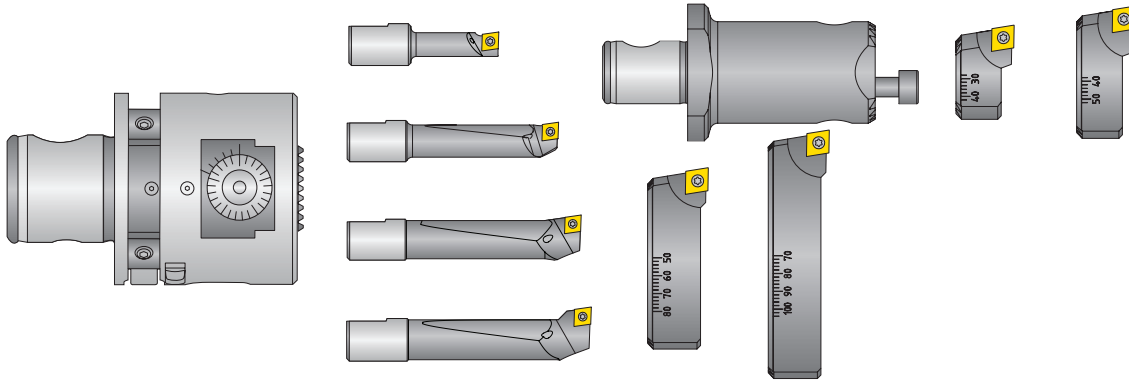

Diameter Range: 0.393" - 4.016" (10.00 mm - 102.00 mm)

Kit Components										
Boring Head	Boring Bars		Serrated Tool Body and Insert Holders			Insert Holders for Boring Head			Service Keys	Kit No.
	Boring Bar Range	Part No.	Serrated Tool Body	Insert Holder Range	Part No.	Insert Holder Range	Part No.	Clamping Piece		
i	0.393 - 0.590	218048	236021	1.142 - 1.614	236023	2.047 - 3.031	236027	236020	115575 (s2.5)	104052
	0.590 - 0.787	081041		1.575 - 2.087	236025	2.992 - 4.016	236029		215403 (s4)	
	0.787 - 0.984	081042							215521 (s5)	
	0.984 - 1.181	081043							115590 (T8)	
m	10.00 - 15.00	218048	236021	29.00 - 41.00	236023	52.00 - 77.00	236027	236020	115575 (s2.5)	103052
	15.00 - 20.00	081041		40.00 - 53.00	236025	76.00 - 102.00	236029		215403 (s4)	
	20.00 - 25.00	081042							215521 (s5)	
	25.00 - 30.00	081043							115590 (T8)	

NOTE: Balancing elements and inserts sold separately



B10-M: 12-15 B10-A: 18 B10-H B10: vi-vii

i = Imperial (in)  
m = Metric (mm)

Inserts sold separately

**IMPORTANT:** Max spindle speed refers to maximum possible speed for an individual boring head and is not a recommended parameter. Refer to page B10-M: 12 for recommended application-specific parameters. Factory technical assistance is available for your specific applications through our Application Engineering department.  
ext: 7611 | email: [appeng@alliedmachine.com](mailto:appeng@alliedmachine.com)

A  
B  
C  
D  
E  
F  
G  
H  
I  
J  
K  
L  
M  
INDEX



## Kit Components

Nondigital | Insert Form 20 | Diameter Range: 0.393" - 4.016" (10.00 mm - 102.00 mm)

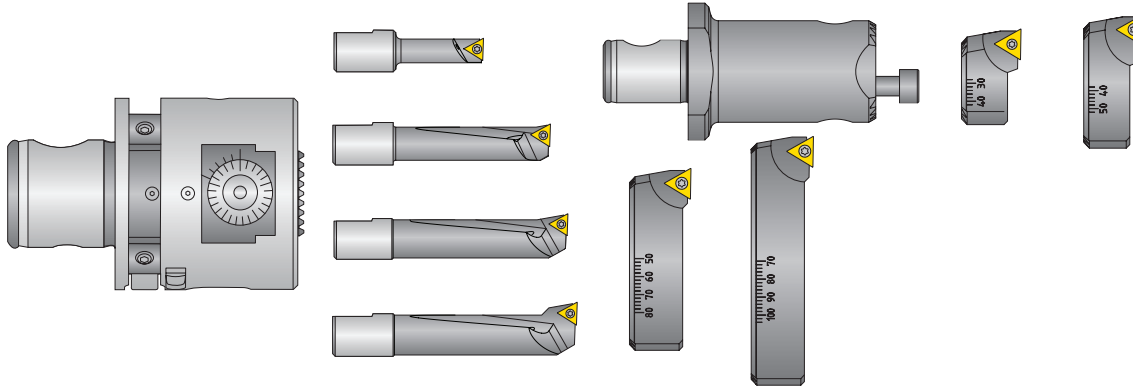

Diameter Range: 0.393" - 4.016" (10.00 mm - 102.00 mm)

Kit Components											
Boring Head	Boring Bars		Serrated Tool Body and Insert Holders			Insert Holders for Boring Head			Service Keys	Kit No.	
	Boring Bar Range	Part No.	Serrated Tool Body	Insert Holder Range	Part No.	Insert Holder Range	Part No.	Clamping Piece			
i	563001	0.393 - 0.590	218059	236021	1.142 - 1.614	236022	2.047 - 3.031	236026	236020	115575 (s2.5)	104051
		0.590 - 0.787	081045		1.575 - 2.087	236024	2.992 - 4.016	236028		215403 (s4)	
		0.787 - 0.984	081046							215521 (s5)	
		0.984 - 1.181	081047							115591 (T7)	
m	536001	10.00 - 15.00	218059	236021	29.00 - 41.00	236022	52.00 - 77.00	236026	236020	115575 (s2.5)	103051
		15.00 - 20.00	081045		40.00 - 53.00	236024	76.00 - 102.00	236028		215403 (s4)	
		20.00 - 25.00	081046							215521 (s5)	
		25.00 - 30.00	081047							115591 (T7)	

NOTE: Balancing elements and inserts sold separately



B10-M: 12-15

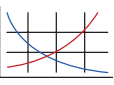

B10-A: 18

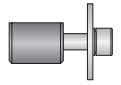

B10-H

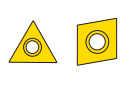

B10: vi-vii



i = Imperial (in)  
m = Metric (mm)

Inserts sold separately

**IMPORTANT:** Max spindle speed refers to maximum possible speed for an individual boring head and is not a recommended parameter. Refer to page B10-M: 12 for recommended application-specific parameters. Factory technical assistance is available for your specific applications through our Application Engineering department.  
ext: 7611 | email: [appeng@alliedmachine.com](mailto:appeng@alliedmachine.com)

A  
B  
C  
D  
E  
F  
G  
H  
I  
J  
K  
L  
M  
INDEX

# 249 (248) Product Overview

## 249 (248) VERSATILE FINE BORING

### Compact design. Precision boring.

The Wohlhaupter® 249 (248) compact boring head allows for higher spindle speeds and achieves long-reach boring jobs. Its cylindrical shank provides variable length adjustments up to 10xD.

Test this *compact design* for finish machining today.

- Diameter range: 0.118" - 1.189" (3.00 mm - 30.20 mm)
- Length adjustment up to 10xD
- Coolant-through boring tool
- 0.0005" (0.01mm) adjust on diameter
- Max spindle speed: 20,000 RPM



**IMPORTANT:** Max spindle speed refers to maximum possible speed for an individual boring head and is not a recommended parameter. Refer to page B10-M: 12 for recommended application-specific parameters. Factory technical assistance is available for your specific applications through our Application Engineering department.  
ext: 7611 | email: [appeng@alliedmachine.com](mailto:appeng@alliedmachine.com)



249 (248) Head



Insert Holder  
Ø 0.626" - 1.189"  
(Ø 15.90 mm - 30.20 mm)



Adapter



Adapter



Boring Bar  
Ø 0.146" - 0.630"  
(Ø 3.70 mm - 16.00 mm)



Mini Boring Bar  
Ø 0.118" - 0.236"  
(Ø 3.00 mm - 6.00 mm)

## OPERATION **VERSATILITY**

from **0.118"** to **1.187"** (3.00 mm to 30.20 mm)



## Boring Heads

Diameter Range: 0.626" - 1.189" (15.90 mm - 30.20 mm)

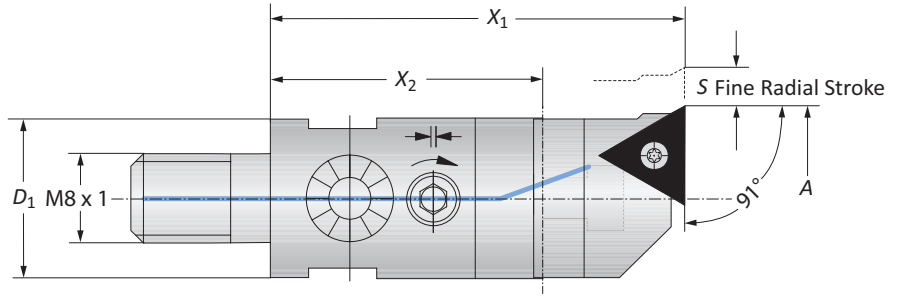

Boring Connection	Boring Range	Boring Head				Weight	Insert Form	Part No.	
		A	X <sub>1</sub>	X <sub>2</sub>	D <sub>1</sub>			Insert Holder	Boring Head
i	M8 x 1	0.626 - 0.791	1.654	1.024	0.591	0.132 (lbs)	20*	248051	249001
	M8 x 1	0.626 - 0.791	1.654	1.024	0.591	0.132 (lbs)	101	248054	249001
	M8 x 1	0.783 - 0.976	1.811	1.181	0.709	0.198 (lbs)	20*	248052	249002
	M8 x 1	0.783 - 0.976	1.811	1.181	0.709	0.198 (lbs)	101	248055	249002
	M8 x 1	0.965 - 1.189	1.811	1.181	0.906	0.287 (lbs)	20*	248053	249003
	M8 x 1	0.965 - 1.189	1.811	1.181	0.906	0.287 (lbs)	101	248056	249003
m	M8 x 1	15.90 - 20.10	42.00	26.00	15.00	0.06 (kg)	20*	248051	248001
	M8 x 1	15.90 - 20.10	42.00	26.00	15.00	0.06 (kg)	101	248054	248001
	M8 x 1	19.90 - 24.80	46.00	30.00	18.00	0.09 (kg)	20*	248052	248002
	M8 x 1	19.90 - 24.80	46.00	30.00	18.00	0.09 (kg)	101	248055	248002
	M8 x 1	24.50 - 30.20	46.00	30.00	23.00	0.13 (kg)	20*	248053	248003
	M8 x 1	24.50 - 30.20	46.00	30.00	23.00	0.13 (kg)	101	248056	248003

\*Not suitable for indexable inserts with a radius of 0.031" (0.80 mm)

B10-M: 12-15

B10-A: 34

B10: vi-vii

Key on B10-A: 1

i = Imperial (in)  
m = Metric (mm)

**IMPORTANT:** Max spindle speed refers to maximum possible speed for an individual boring head and is not a recommended parameter. Refer to page B10-M: 12 for recommended application-specific parameters. Factory technical assistance is available for your specific applications through our Application Engineering department.  
ext: 7611 | email: [appeng@alliedmachine.com](mailto:appeng@alliedmachine.com)

### Mini Boring Bars

WHC05 | WHW04 | WBN150 | Diameter Range: 0.118" - 0.236" (3.00 mm - 6.00 mm)

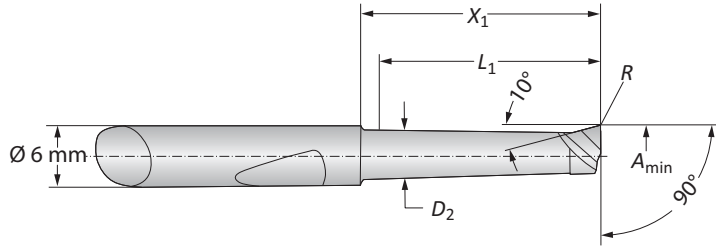

#### Mini Boring Bars

Boring Range	Boring Bar					Part No.			
	$A_{min}$	$D_1$	$D_2$	$X_1$	$L_1$	$R$	Coated Carbide	Uncoated Carbide	CBN
i	0.118	0.236	0.102	0.452	0.393	0.003	081306WHC05	-	081322WBN150
	0.118	0.236	0.102	0.649	0.590	0.003	081307WHC05	081307WHW04	-
	0.157	0.236	0.141	0.472	0.393	0.007	081308WHC05	-	081317WBN150
	0.157	0.236	0.141	0.669	0.590	0.007	081309WHC05	-	081341WBN150
	0.157	0.236	0.141	0.866	0.787	0.007	081310WHC05	081310WHW04	-
	0.196	0.236	0.181	0.472	0.393	0.007	081311WHC05	-	081318WBN150
	0.196	0.236	0.181	0.866	0.787	0.007	081312WHC05	-	081319WBN150
	0.196	0.236	0.181	1.259	1.181	0.007	081313WHC05	081313WHW04	-
	0.236	0.236	0.220	0.866	0.787	0.007	081314WHC05	-	081320WBN150
	0.236	0.236	0.220	1.259	1.181	0.007	081315WHC05	-	081321WBN150
0.236	0.236	0.220	1.653	1.574	0.007	081316WHC05	081316WHW04	-	
m	3.00	6.00	2.60	11.50	10.00	0.10	081306WHC05	-	081322WBN150
	3.00	6.00	2.60	16.50	15.00	0.10	081307WHC05	081307WHW04	-
	4.00	6.00	3.60	12.00	10.00	0.20	081308WHC05	-	081317WBN150
	4.00	6.00	3.60	17.00	15.00	0.20	081309WHC05	-	081341WBN150
	4.00	6.00	3.60	22.00	20.00	0.20	081310WHC05	081310WHW04	-
	5.00	6.00	4.60	12.00	10.00	0.20	081311WHC05	-	081318WBN150
	5.00	6.00	4.60	22.00	20.00	0.20	081312WHC05	-	081319WBN150
	5.00	6.00	4.60	32.00	30.00	0.20	081313WHC05	081313WHW04	-
	6.00	6.00	5.60	22.00	20.00	0.20	081314WHC05	-	081320WBN150
	6.00	6.00	5.60	32.00	30.00	0.20	081315WHC05	-	081321WBN150
6.00	6.00	5.60	42.00	40.00	0.20	081316WHC05	081316WHW04	-	

#### Adapter

Boring Head	Adapter				Part No.
	$X_1$	$D_1$	$D_2$	$D_3$	
i 249003	1.260	0.906	0.236	0.866	248071
m 248003	32.00	23.00	6.00	22.00	248071

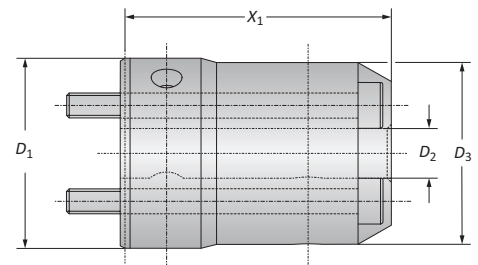

B10-M: 12-15

B10-A: 34

B10: vi-vii

i = Imperial (in)  
m = Metric (mm)

A  
B  
C  
D  
E  
F  
G  
H  
I  
J  
K  
L  
M  
INDEX

## Boring Bars

Diameter Range: 0.146" - 0.630" (3.70 mm - 16.00 mm)

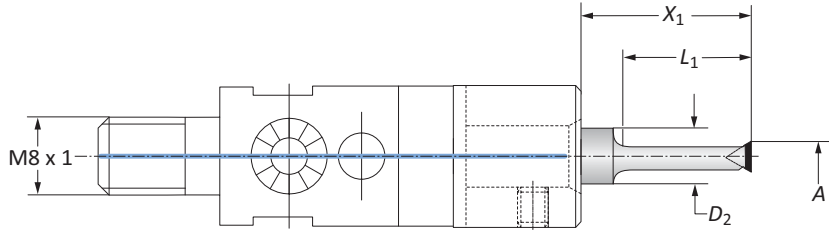

### Boring Bars

Boring Range	Boring Bar				Insert Form	Part No.
	A	D <sub>2</sub>	X <sub>1</sub>	L <sub>1</sub>		
0.146 - 0.197	0.315	0.819	0.709	325*	218074	
0.193 - 0.236	0.315	1.024	0.906	47*	218075	
0.232 - 0.315	0.315	1.063	0.984	211*	218076	
0.311 - 0.394	0.315	1.201	1.181	211*	218077	
0.390 - 0.472	0.315	1.378	1.378	20*	218079	
0.390 - 0.472	0.315	1.378	1.378	101	218082	
0.469 - 0.551	0.394	1.772	1.772	20*	218080	
0.469 - 0.551	0.394	1.772	1.772	101	218083	
0.547 - 0.630	0.394	1.969	1.968	20*	218081	
0.547 - 0.630	0.394	1.969	1.968	101	218084	
<hr/>						
3.70 - 5.00	8.00	20.80	18.00	325*	218074	
4.90 - 6.00	8.00	26.00	23.00	47*	218075	
5.90 - 8.00	8.00	27.00	25.00	211*	218076	
7.90 - 10.00	8.00	30.50	30.00	211*	218077	
9.90 - 12.00	8.00	35.00	35.00	20*	218079	
9.90 - 12.00	8.00	35.00	35.00	101	218082	
11.90 - 14.00	10.00	45.00	45.00	20*	218080	
11.90 - 14.00	10.00	45.00	45.00	101	218083	
13.90 - 16.00	10.00	50.00	50.00	20*	218081	
13.90 - 16.00	10.00	50.00	50.00	101	218084	

\*Not suitable for indexable inserts with a radius of 0.031" (0.80 mm)

### Adapters

Boring Head	Adapter		Part No.
	D <sub>1</sub>	D <sub>2</sub>	
249002	0.709	0.315	248063
249003	0.906	0.315	248064
249003	0.906	0.394	248065
<hr/>			
248002	18.00	8.00	248063
248003	23.00	8.00	248064
248003	23.00	10.00	248065

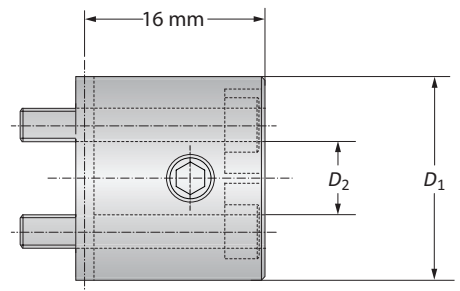

B10-M: 12-15

B10-H

B10: vi-vii

Key on B10-A: 1

i = Imperial (in)  
m = Metric (mm)  
Inserts sold separately



## Adapters

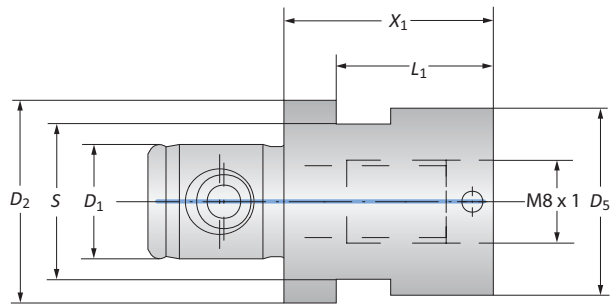

### Adapters

	MVS Connection		Adapter				Weight	Service Key	Part No.
	$D_2   D_1$	Boring Connection	$X_1$	$L_1$	$S$	$D_5$			
i	19.5 - 11	M8 x 1	0.787	0.590	15/P	0.708	0.110 (lbs)	15 S / P	219168
	23 - 11	M8 x 1	0.787	-	19/P	0.905	0.154 (lbs)	19 S / P	219169
m	19.5 - 11	M8 x 1	20.00	15.00	15/P	18.00	0.05 (kg)	15 S / P	219168
	23 - 11	M8 x 1	20.00	-	19/P	23.00	0.07 (kg)	19 S / P	219169

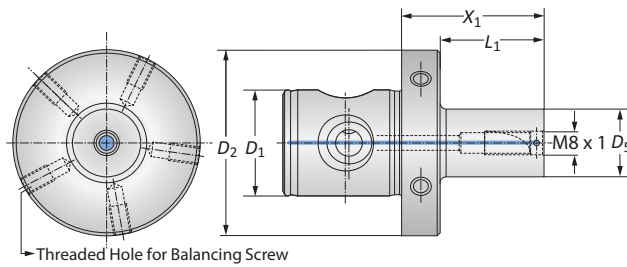

### Balanced Adapters

	MVS Connection		Adapter				Weight	Balancing Screw	Part No.
	$D_2   D_1$	Boring Connection	$X_1$	$L_1$	$D_5$				
i	50 - 28	M8 x 1	1.259	0.748	0.590	0.771 (lbs)	M6 x 1 x 10	219185	
	50 - 28	M8 x 1	1.890	1.377	0.708	0.881 (lbs)	M6 x 1 x 10	219176	
	50 - 28	M8 x 1	1.890	1.377	0.905	0.992 (lbs)	M6 x 1 x 10	219177	
m	50 - 28	M8 x 1	32.00	19.00	15.00	0.35 (kg)	M6 x 1 x 10	219185	
	50 - 28	M8 x 1	48.00	35.00	18.00	0.40 (kg)	M6 x 1 x 10	219176	
	50 - 28	M8 x 1	48.00	35.00	23.00	0.45 (kg)	M6 x 1 x 10	219177	

NOTE: Balance refers to a specific residual imbalance of  $\leq 10$  g mm/kg

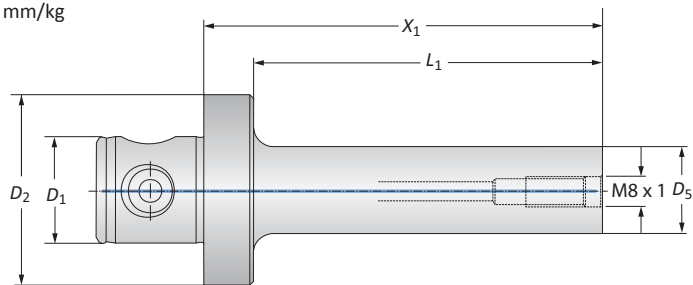

### Vibration Reducing Heavy Metal Adapters

	MVS Connection		Adapter				Weight	Part No.
	$D_2   D_1$	Boring Connection	$X_1$	$L_1$	$D_5$			
i	50 - 28	M8 x 1	2.677	2.165	0.590	1.763 (lbs)	248147	
	50 - 28	M8 x 1	3.307	2.795	0.748	2.204 (lbs)	248148	
	50 - 28	M8 x 1	4.094	3.582	0.905	2.866 (lbs)	248149	
m	50 - 28	M8 x 1	68.00	55.00	15.00	0.80 (kg)	248147	
	50 - 28	M8 x 1	84.00	71.00	19.00	1.00 (kg)	248148	
	50 - 28	M8 x 1	104.00	91.00	23.00	1.30 (kg)	248149	

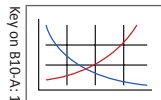
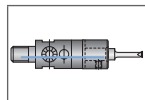
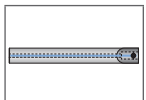
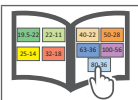





i = Imperial (in)  
m = Metric (mm)

A  
B  
C  
D  
E  
F  
G  
H  
I  
J  
K  
L  
M  
INDEX

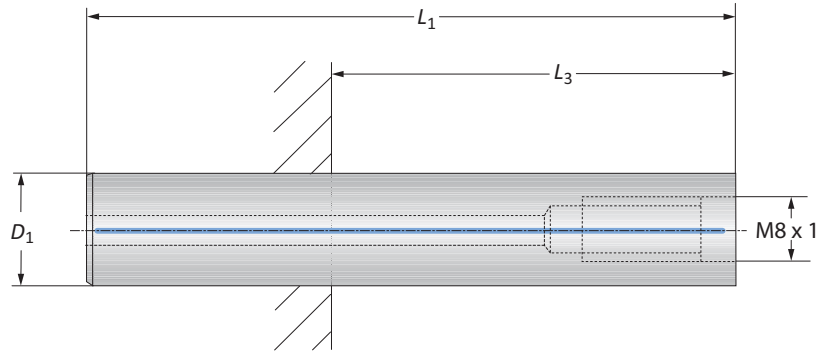
## Shanks

Steel | Carbide



### Steel Shanks

Connection	Shank			$L_3$ min*			Weight	Part No.
	$D_1$	$L_1$	$L_3$ max*	SK 40+50	HSK-A 63	HSK-A 100		
i	M8 x 1	0.591	3.346	1.456	-	-	0.220 (lbs)	248136
	M8 x 1	0.709	3.937	2.047	-	0.196	0.440 (lbs)	248137
	M8 x 1	0.906	4.606	2.716	-	0.866	0.881 (lbs)	248138
m	M8 x 1	15.00	85.00	37.00	-	-	0.10 (kg)	248136
	M8 x 1	18.00	100.00	52.00	-	5.00	0.20 (kg)	248137
	M8 x 1	23.00	117.00	69.00	-	22.00	0.40 (kg)	248138

\* $L_3$  dimensions apply to collet chucks

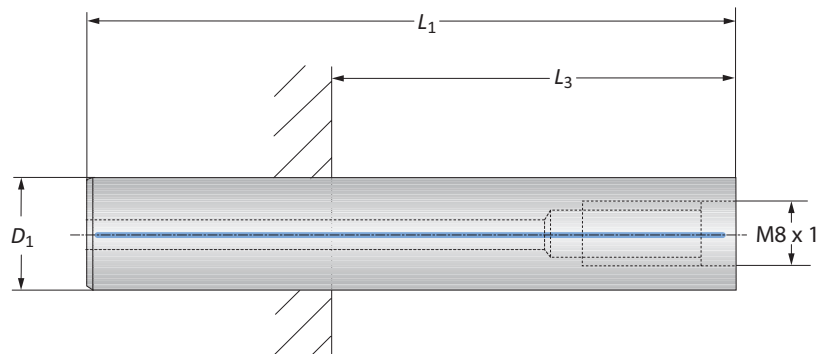

### Carbide Shanks

Connection	Shank			$L_3$ min*				Weight	Part No.	
	$D_1$	$L_1$	$L_3$ max*	SK 40	SK 50	HSK-A 63	HSK-A 100			
i	M8 x 1	0.591	5.118	3.228	0.787	0.787	1.377	1.653	0.661 (lbs)	248142
	M8 x 1	0.709	6.102	4.212	1.535	0.826	2.362	2.637	1.322 (lbs)	248143
	M8 x 1	0.906	7.086	5.196	2.519	1.811	3.346	3.622	2.425 (lbs)	248144
	M8 x 1	0.906	9.527	7.637	4.960	4.251	5.787	6.062	3.086 (lbs)	248145
m	M8 x 1	15.00	130.00	82.00	20.00	20.00	35.00	42.00	0.30 (kg)	248142
	M8 x 1	18.00	155.00	107.00	39.00	21.00	60.00	67.00	0.60 (kg)	248143
	M8 x 1	23.00	180.00	132.00	64.00	46.00	85.00	92.00	1.10 (kg)	248144
	M8 x 1	23.00	242.00	194.00	126.00	108.00	147.00	154.00	1.40 (kg)	248145

\* $L_3$  dimensions apply to collet chucks

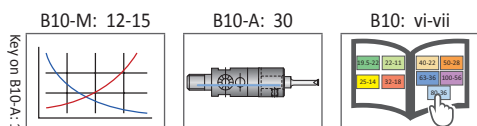

i = Imperial (in)  
m = Metric (mm)

## Accessories

### Clamping Elements

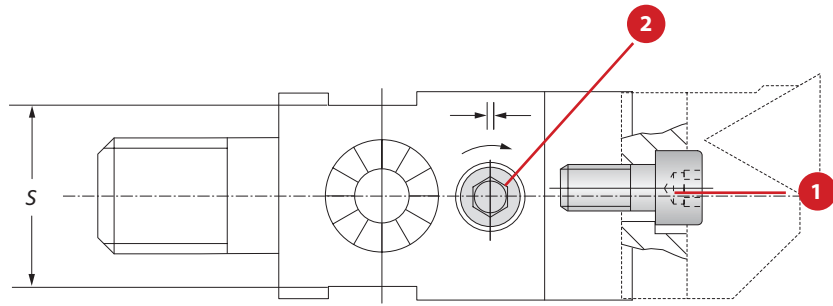

#### Clamping Elements for Boring Heads

Boring Head	Service Key S / Type	1 Cap Screw		2 Set Screw		
		Part No.	Service Key	Part No.	Service Key	
i	249001	13 S / P	315631	s3 / A	315629	s2 / A
	249002	15 S / P	315631	s3 / A	315684	s2 / A
	249003	19 S / P	315631	s3 / A	315687	s2 / A
m	248001	13 S / P	315631	s3 / A	315629	s2 / A
	248002	15 S / P	315631	s3 / A	315684	s2 / A
	248003	19 S / P	315631	s3 / A	315687	s2 / A

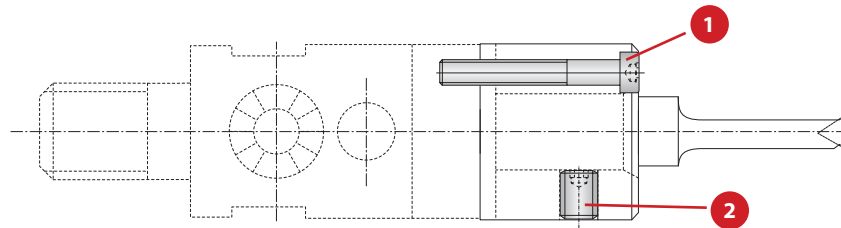

#### Clamping Elements for Adapters

Adapters	1 Cap Screw		2 Set Screw		
	Part No.	Service Key	Part No.	Service Key	
m	248063	315801	S 2.5 / A	115136	S 2.5 / A
	248064	315801	S 2.5 / A	031141	S 2.5 / A
	248065	315801	S 2.5 / A	031141	S 2.5 / A

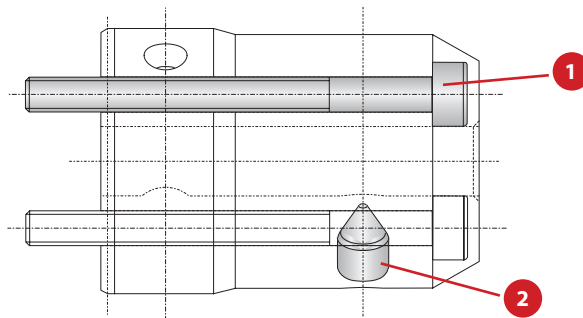

#### Screws for Adapter

Adapters	1 Cap Screw		2 Set Screw		
	Part No.	Service Key	Part No.	Service Key	
m	248071	515166	S 2.5 / A	415244	S 3 / A

i = Imperial (in)  
m = Metric (mm)

A  
B  
C  
D  
E  
F  
G  
H  
I  
J  
K  
L  
M  
INDEX

# PrimeBore Product Overview

## PrimeBore VERSATILE FINE BORING

### Advancing versatile technology.

With over 30 years of development, the Wohlhaupter® PrimeBore boring head offers versatility and precision. The PrimeBore head can bore multiple hole sizes ranging from 0.118" - 8.189" (3.00 mm - 208.00 mm) with our broad range of compatible boring bars.

Complete your boring job with *technology that continues to advance.*

- Diameter range: 0.118" - 8.189" (3.00 mm - 208.00 mm)
- Ease the stress of working on different day-to-day projects with boring kits
- 0.0001" (0.002 mm) adjust on diameter
- Economical precision and versatility
- Max spindle speed: 12,000 RPM
- Coolant through



**IMPORTANT:** Max spindle speed refers to maximum possible speed for an individual boring head and is not a recommended parameter. Refer to page B10-M: 12 for recommended application-specific parameters. Factory technical assistance is available for your specific applications through our Application Engineering department.  
ext: 7611 | email: [appeng@alliedmachine.com](mailto:appeng@alliedmachine.com)



# PRIME BORE



PrimeBore Head

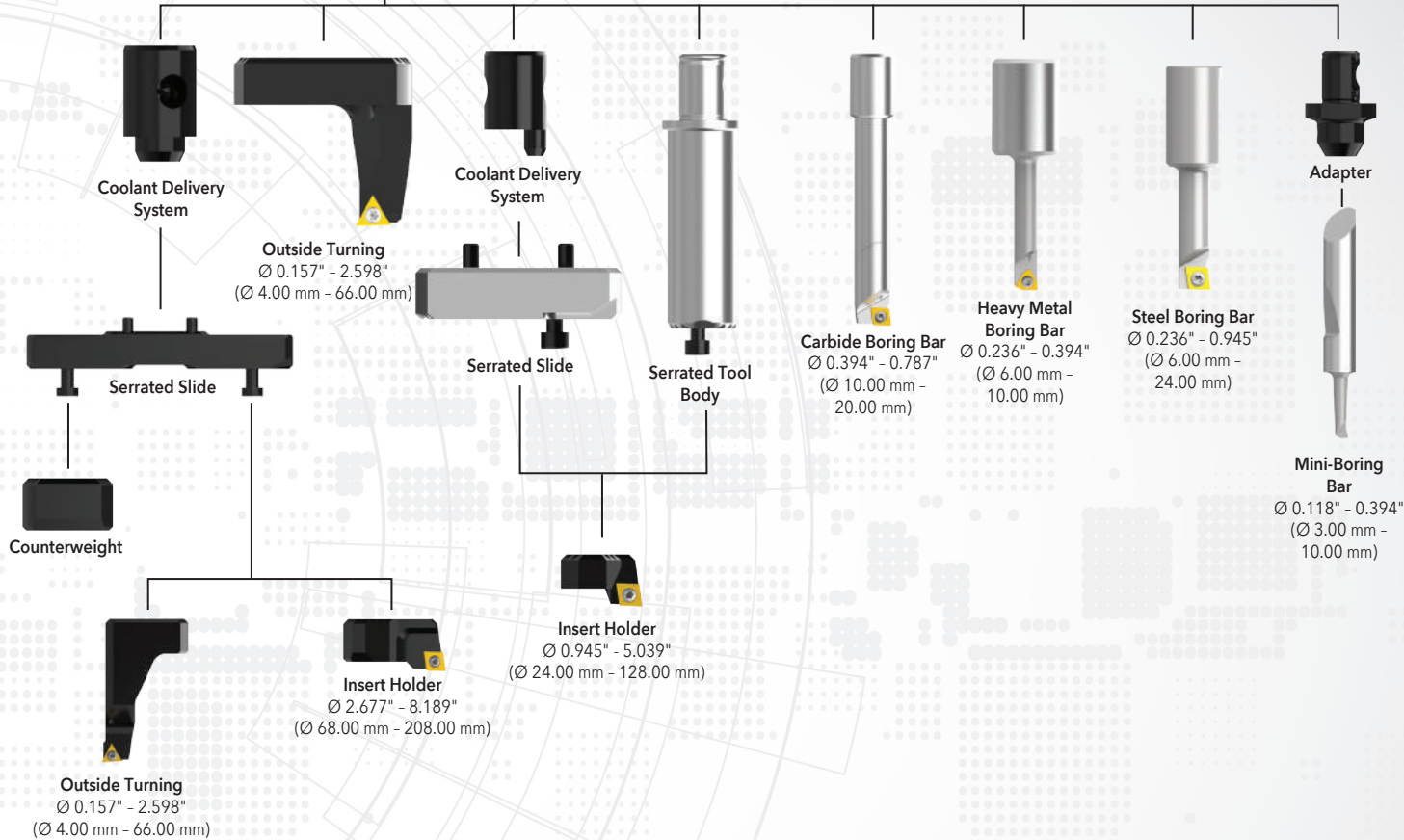

## OPERATION **VERSATILITY**

from **0.118"** to **8.189"** (3.00 mm to 208.00 mm)  
*plus outside turning*



## Boring Heads

Diameter Range: 0.118" - 8.189" (3.00 mm - 208.00 mm)

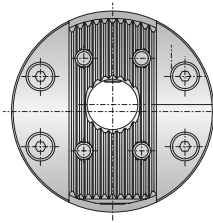

+ 4.5 mm  
- 0.1 mm  
Fine Radial Stroke

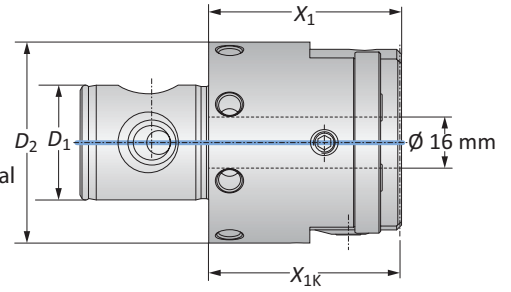

	MVS Connection		Boring Head		Weight	Part No.
	$D_2$   $D_1$	Boring Range	$X_1$	$X_{1K}$		
<b>i</b>	63 - 36	0.118 - 8.189	2.362	2.343	2.866 (lbs)	451001
<b>m</b>	63 - 36	3.00 - 208.00	60.00	59.50	1.30 (kg)	450001

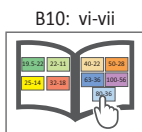
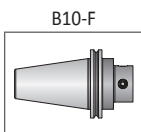
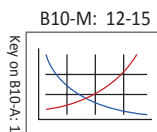

**i** = Imperial (in)  
**m** = Metric (mm)

**IMPORTANT:** Max spindle speed refers to maximum possible speed for an individual boring head and is not a recommended parameter. Refer to page B10-M: 12 for recommended application-specific parameters. Factory technical assistance is available for your specific applications through our Application Engineering department.  
ext: 7611 | email: [appeng@alliedmachine.com](mailto:appeng@alliedmachine.com)



## Mini Boring Bars

WHC05 | WHW04 | WBN150 | Diameter Range: 0.118" - 0.394" (3.00 mm - 10.00 mm)

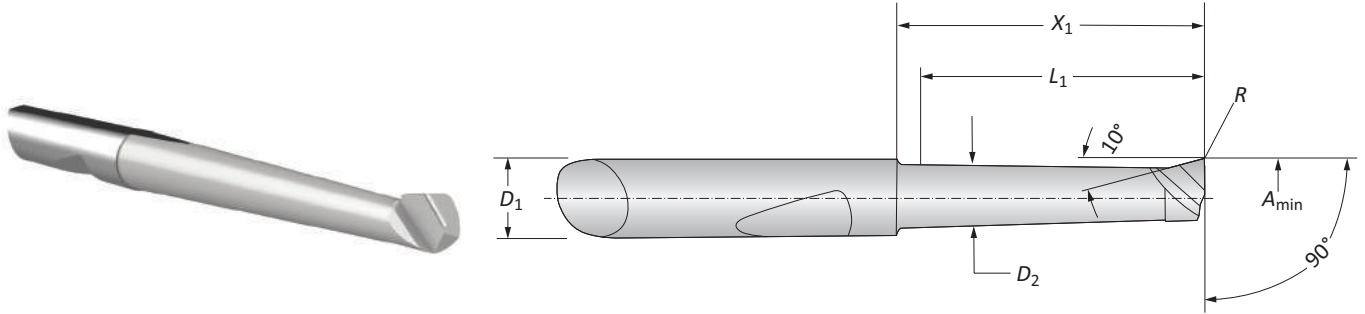

### Mini Boring Bars

Boring Range	Boring Bar					Part No.			
	$A_{min}$	$D_1$	$D_2$	$X_1$	$L_1$	$R$	Coated Carbide	Uncoated Carbide	CBN
i	0.118	0.236	0.102	0.452	0.393	0.003	081306WHC05	-	081322WBN150
	0.118	0.236	0.102	0.649	0.590	0.003	081307WHC05	081307WHW04	-
	0.157	0.236	0.141	0.472	0.393	0.007	081308WHC05	-	081317WBN150
	0.157	0.236	0.141	0.669	0.590	0.007	081309WHC05	-	081341WBN150
	0.157	0.236	0.141	0.866	0.787	0.007	081310WHC05	081310WHW04	-
	0.196	0.236	0.181	0.472	0.393	0.007	081311WHC05	-	081318WBN150
	0.196	0.236	0.181	0.866	0.787	0.007	081312WHC05	-	081319WBN150
	0.196	0.236	0.181	1.259	1.181	0.007	081313WHC05	081313WHW04	-
	0.236	0.236	0.220	0.866	0.787	0.007	081314WHC05	-	081320WBN150
	0.236	0.236	0.220	1.259	1.181	0.007	081315WHC05	-	081321WBN150
	0.236	0.236	0.220	1.653	1.574	0.007	081316WHC05	081316WHW04	-
	0.315	0.315	0.229	0.984	0.905	0.007	081323WHC05	-	-
	0.315	0.315	0.229	1.968	1.889	0.007	081324WHC05	-	-
	m	3.00	6.00	2.60	11.50	10.00	0.10	081306WHC05	-
3.00		6.00	2.60	16.50	15.00	0.10	081307WHC05	081307WHW04	-
4.00		6.00	3.60	12.00	10.00	0.20	081308WHC05	-	081317WBN150
4.00		6.00	3.60	17.00	15.00	0.20	081309WHC05	-	081341WBN150
4.00		6.00	3.60	22.00	20.00	0.20	081310WHC05	081310WHW04	-
5.00		6.00	4.60	12.00	10.00	0.20	081311WHC05	-	081318WBN150
5.00		6.00	4.60	22.00	20.00	0.20	081312WHC05	-	081319WBN150
5.00		6.00	4.60	32.00	30.00	0.20	081313WHC05	081313WHW04	-
6.00		6.00	5.60	22.00	20.00	0.20	081314WHC05	-	081320WBN150
6.00		6.00	5.60	32.00	30.00	0.20	081315WHC05	-	081321WBN150
6.00		6.00	5.60	42.00	40.00	0.20	081316WHC05	081316WHW04	-
8.00		8.00	7.60	25.00	23.00	0.20	081323WHC05	-	-
8.00		8.00	7.60	50.00	48.00	0.20	081324WHC05	-	-



### Adapters

	Adapter				Part No.
	$D_3$	$D_5$	$X_1$	$L_1$	
m	6.00	20.00	22.50	14.00	319010
	8.00	22.00	22.50	14.00	236071

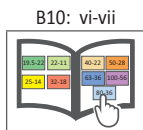
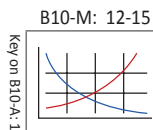
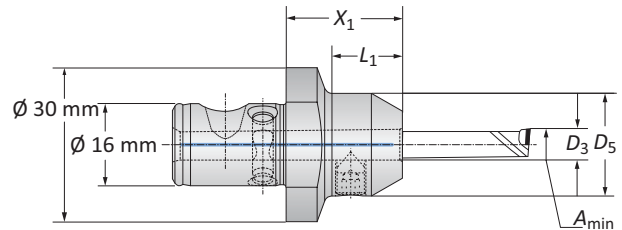

i = Imperial (in)  
m = Metric (mm)

A  
B  
C  
D  
E  
F  
G  
H  
I  
J  
K  
L  
M  
INDEX

## Boring Bars

Steel | Heavy Metal | Diameter Range: 0.236" - 0.945" (6.00 mm - 24.00 mm)

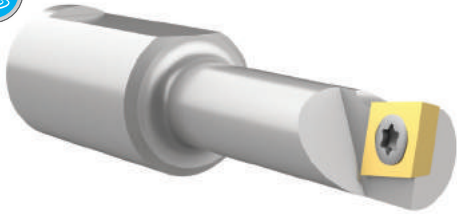

Form 101

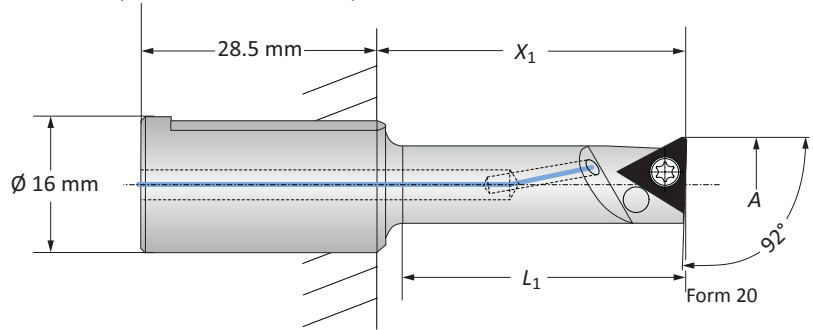

Steel Boring Bars | Diameter Range: 0.236" - 0.945" (6.00 mm - 24.00 mm)

	Boring Range		Boring Bar		Weight	Insert Form	Part No.
	A	X <sub>1</sub>	L <sub>1</sub>				
i	0.236 - 0.394	0.866 - 1.260	0.787		0.090 (lbs)	211*	450026
	0.394 - 0.630	1.378 - 1.772	1.299		0.130 (lbs)	101	450027
	0.394 - 0.630	1.378 - 1.772	1.299		0.130 (lbs)	20*	450038
	0.630 - 0.945	2.362 - 2.756	2.283		0.220 (lbs)	101	450028
	0.630 - 0.945	2.362 - 2.756	2.283		0.220 (lbs)	20*	450039
m	6.00 - 10.00	22.00 - 32.00	20.00		0.04 (kg)	211*	450026
	10.00 - 16.00	35.00 - 45.00	33.00		0.06 (kg)	101	450027
	10.00 - 16.00	35.00 - 45.00	33.00		0.06 (kg)	20*	450038
	16.00 - 24.00	60.00 - 70.00	58.00		0.10 (kg)	101	450028
	16.00 - 24.00	60.00 - 70.00	58.00		0.10 (kg)	20*	450039

\*Not suitable for indexable inserts with a radius of 0.031" (0.80 mm)

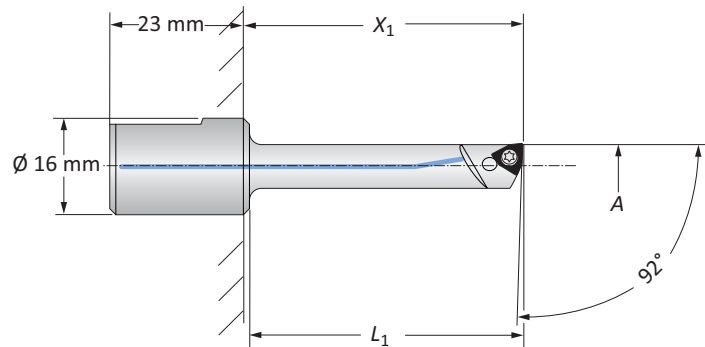

Heavy Metal Boring Bars | Diameter Range: 0.236" - 0.394" (6.00 mm - 10.00 mm)

	Boring Range		Boring Bar		Weight	Insert Form	Part No.
	A	X <sub>1</sub>	L <sub>1</sub>				
i	0.236 - 0.315	1.260	1.142		0.176 (lbs)	211*	081055
	0.315 - 0.394	1.772	1.654		0.198 (lbs)	211*	218072
m	6.00 - 8.00	32.00	29.00		0.08 (kg)	211*	081055
	8.00 - 10.00	45.00	42.00		0.09 (kg)	211*	218072

\*Not suitable for indexable inserts with a radius of 0.031" (0.80 mm)

B10-M: 12-15

B10-H

B10: vi-vii

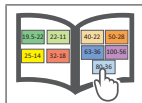
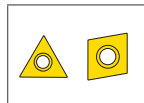
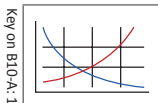

i = Imperial (in)  
m = Metric (mm)

Inserts sold separately

## Boring Bars

Carbide | Diameter Range: 0.393" - 0.787" (10.00 mm - 20.00 mm)



Form 101

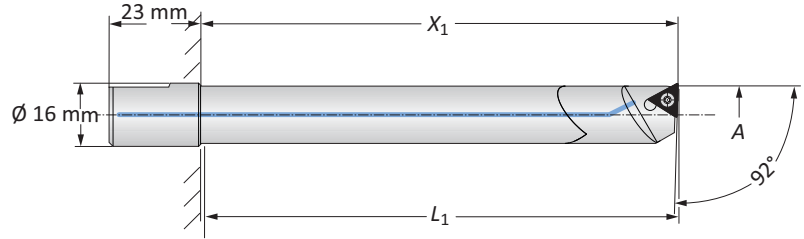

Form 20

### Carbide Boring Bars

	Boring Range		Boring Bar		Weight	Insert Form	Part No.	Insert Form	Part No.
	A	X <sub>1</sub>	L <sub>1</sub>						
i	0.394 - 0.472	2.165	2.047		0.154 (lbs)	101	<b>218042</b>	20*	<b>218037</b>
	0.394 - 0.472	2.953	2.835		0.198 (lbs)	101	<b>218032</b>	20*	<b>218029</b>
	0.472 - 0.551	2.756	2.638		0.220 (lbs)	101	<b>218043</b>	20*	<b>218038</b>
	0.472 - 0.551	3.543	3.425		0.331 (lbs)	101	<b>218033</b>	20*	<b>218030</b>
	0.551 - 0.630	2.953	2.835		0.353 (lbs)	101	<b>218044</b>	20*	<b>218039</b>
	0.551 - 0.630	3.937	3.819		0.441 (lbs)	101	<b>218045</b>	20*	<b>218040</b>
	0.630 - 0.787	3.543	3.425		0.573 (lbs)	101	<b>218046</b>	20*	<b>218041</b>
	0.630 - 0.787	4.724	4.606		0.728 (lbs)	101	<b>218034</b>	20*	<b>218031</b>
m	10.00 - 12.00	55.00	52.00		0.07 (kg)	101	<b>218042</b>	20*	<b>218037</b>
	10.00 - 12.00	75.00	72.00		0.09 (kg)	101	<b>218032</b>	20*	<b>218029</b>
	12.00 - 14.00	70.00	67.00		0.10 (kg)	101	<b>218043</b>	20*	<b>218038</b>
	12.00 - 14.00	90.00	87.00		0.15 (kg)	101	<b>218033</b>	20*	<b>218030</b>
	14.00 - 16.00	75.00	72.00		0.16 (kg)	101	<b>218044</b>	20*	<b>218039</b>
	14.00 - 16.00	100.00	97.00		0.20 (kg)	101	<b>218045</b>	20*	<b>218040</b>
	16.00 - 20.00	90.00	87.00		0.26 (kg)	101	<b>218046</b>	20*	<b>218041</b>
	16.00 - 20.00	120.00	117.00		0.33 (kg)	101	<b>218034</b>	20*	<b>218031</b>

\*Not suitable for indexable inserts with a radius of 0.031" (0.80 mm)

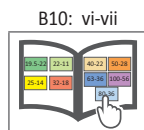
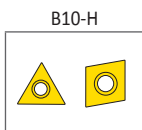
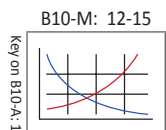

i = Imperial (in)  
 m = Metric (mm)  
 Inserts sold separately

A  
B  
C  
D  
E  
F  
G  
H  
I  
J  
K  
L  
M  
INDEX

## Serrated Tool Bodies | Insert Holders

Diameter Range: 0.945" - 2.559" (24.00 mm - 65.00 mm)

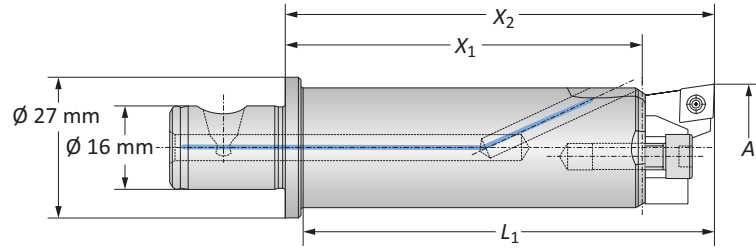

### Serrated Tool Bodies

	Boring Range	Serrated Tool Body			Weight	Part No.
	A	X <sub>1</sub>	X <sub>2</sub>	L <sub>1</sub>		
<b>i</b>	0.945 - 2.559	2.667	3.228	3.110	0.441 (lbs)	<b>450021</b>
<b>m</b>	24.00 - 65.00	68.00	82.00	79.00	0.20 (kg)	<b>450021</b>

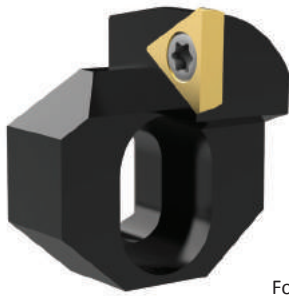

Form 20

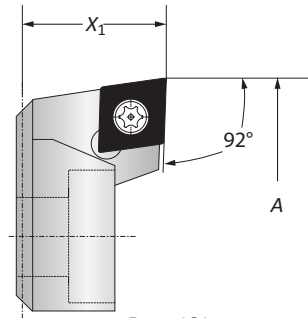

Form 101

### Insert Holders

	Boring Range	Insert Holder	Weight	Insert Form	Part No.
	A	X <sub>1</sub>			
<b>i</b>	0.945 - 1.575	0.551	0.044 (lbs)	101	<b>450022</b>
	0.945 - 1.575	0.551	0.044 (lbs)	20*	<b>450040</b>
	1.575 - 2.559	0.551	0.066 (lbs)	101	<b>450023</b>
	1.575 - 2.559	0.551	0.066 (lbs)	20*	<b>450041</b>
<b>m</b>	24.00 - 40.00	14.00	0.02 (kg)	101	<b>450022</b>
	24.00 - 40.00	14.00	0.02 (kg)	20*	<b>450040</b>
	40.00 - 65.00	14.00	0.03 (kg)	101	<b>450023</b>
	40.00 - 65.00	14.00	0.03 (kg)	20*	<b>450041</b>

\*Not suitable for indexable inserts with a radius of 0.031" (0.80 mm)

B10-M: 12-15

Key on B10-A: 1

B10-A: 47

B10-H

B10: vi-vii

**i** = Imperial (in)  
**m** = Metric (mm)  
 Inserts sold separately

## Serrated Slides | Insert Holders

Diameter Range: 2.559" - 5.039" (65.00 mm - 128.00 mm)

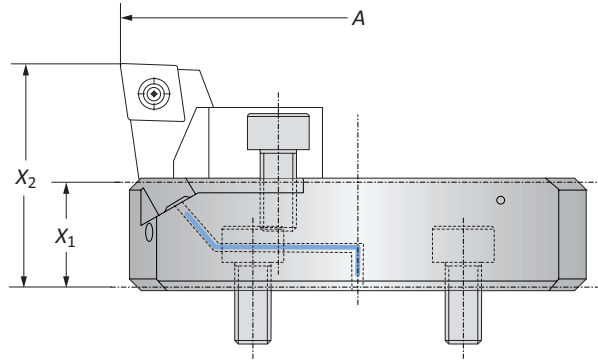
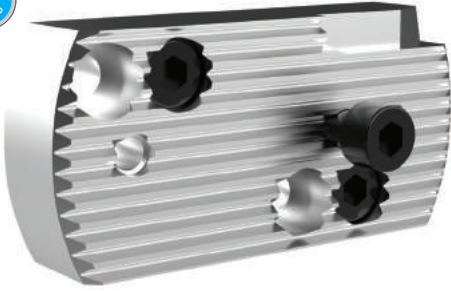

### Serrated Slides

	Boring Range	Serrated Slide		Weight	Part No.
	A	X <sub>1</sub>	X <sub>2</sub>		
<b>i</b>	2.559 - 5.039	0.571	1.161	0.176 (lbs)	<b>450024</b>
<b>m</b>	65.00 - 128.00	14.50	29.50	0.08 (kg)	<b>450024</b>

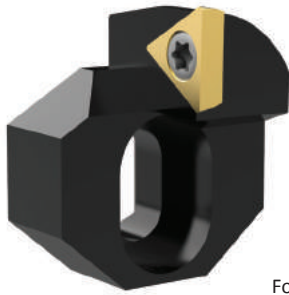

Form 20

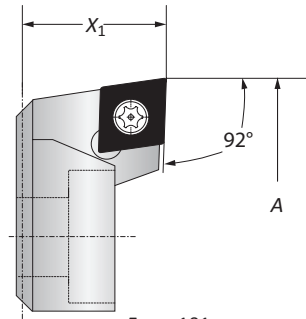

Form 101

### Insert Holders

	Boring Range	Insert Holder	Weight	Insert Form	Part No.
	A	X <sub>1</sub>			
<b>i</b>	2.559 - 5.039	0.551	0.066 (lbs)	101	<b>450023</b>
	2.559 - 5.039	0.551	0.066 (lbs)	20*	<b>450041</b>
<b>m</b>	65.00 - 128.00	14.00	0.03 (kg)	101	<b>450023</b>
	65.00 - 128.00	14.00	0.03 (kg)	20*	<b>450041</b>



\*Not suitable for indexable inserts with a radius of 0.031" (0.80 mm)

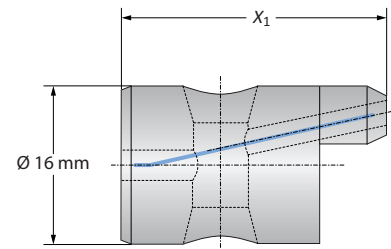

### Alu-Line Coolant Delivery Sections

	Coolant Delivery Section		Part No.
	X <sub>1</sub>	Weight	
<b>m</b>	26.75	0.01 (kg)	<b>450125</b>

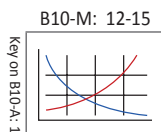
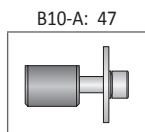
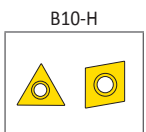







**i** = Imperial (in)  
**m** = Metric (mm)  
 Inserts sold separately

A  
B  
C  
D  
E  
F  
G  
H  
I  
J  
K  
L  
M  
INDEX

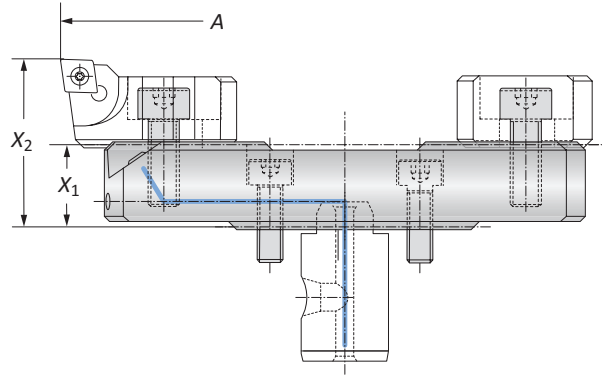
## Alu-Line Serrated Slides | Insert Holders

Diameter Range: 2.667" - 8.189" (68.00 mm - 208.00 mm)



### Alu-Line Serrated Slides

	Boring Range		Serrated Slide		Weight	Part No.
	A		X <sub>1</sub>	X <sub>2</sub>		
i	2.667 - 3.780		0.630	1.280	0.220 (lbs)	501054
	3.780 - 4.882		0.630	1.280	0.220 (lbs)	501055
	4.882 - 5.984		0.630	1.280	0.441 (lbs)	501056
	5.984 - 7.087		0.866	1.516	0.551 (lbs)	501058
	7.087 - 8.189		0.866	1.516	0.661 (lbs)	501059
m	68.00 - 96.00		16.00	32.50	0.10 (kg)	501054
	96.00 - 124.00		16.00	32.50	0.10 (kg)	501055
	124.00 - 152.00		16.00	32.50	0.20 (kg)	501056
	152.00 - 180.00		22.00	38.50	0.25 (kg)	501058
	180.00 - 208.00		22.00	38.50	0.30 (kg)	501059

### Insert Holders

	Boring Range		Insert Form	Part No.
	A	Weight		
i	2.677 - 8.189	0.110 (lbs)	101	502064
	2.677 - 8.189	0.110 (lbs)	20	502069
m	68.00 - 208.00	0.05 (kg)	101	502064
	68.00 - 208.00	0.05 (kg)	20	502069



Form 20

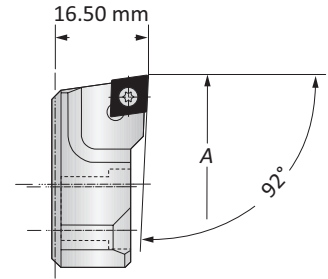

Form 101

NOTE: Other insert holders available upon request

### Counterweights

	Counterweights		Part No.
	X <sub>1</sub>	Weight	
i	0.528	0.110 (lbs)	502165
m	13.40	0.05 (kg)	502165

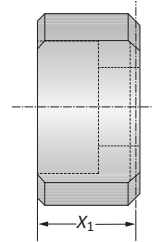

### Alu-Line Coolant Delivery Sections

	Coolant Delivery Section		Part No.
	X <sub>1</sub>	Weight	
i	1.004	0.022 (lbs)	450137
m	25.50	0.01 (kg)	450137

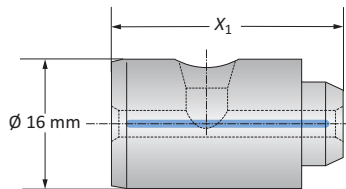

B10-M: 12-15

B10-A: 47

B10-H

B10: vi-vii

Key on B10-A: 1

i = Imperial (in)  
m = Metric (mm)

Inserts sold separately



## Outside Turning Insert Holders for Boring Heads

Diameter Range: 0.157" - 2.598" (4.00 mm - 66.00 mm)

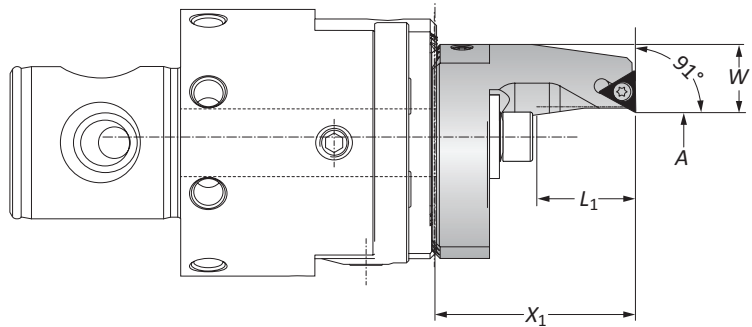

**Type A Insert Holders | Diameter Range: 0.157" - 1.181" (4.00 mm - 30.00 mm)**

	Boring Range		Insert Holder				Weight	Type	Insert Form	Part No.
	A	X <sub>1</sub>	L <sub>1</sub>	W						
i	0.157 - 0.689	1.594	0.787	0.653	0.220 (lbs)	A	20*	236081		
	0.650 - 1.181	1.988	1.181	0.437	0.220 (lbs)	A	20*	236082		
m	4.00 - 17.50	40.50	20.00	16.60	0.10 (kg)	A	20*	236081		
	16.50 - 30.00	50.50	30.00	11.10	0.10 (kg)	A	20*	236082		

**NOTE:** Clockwise and neutral execution

\*Not suitable for indexable inserts with a radius of 0.031" (0.80 mm)

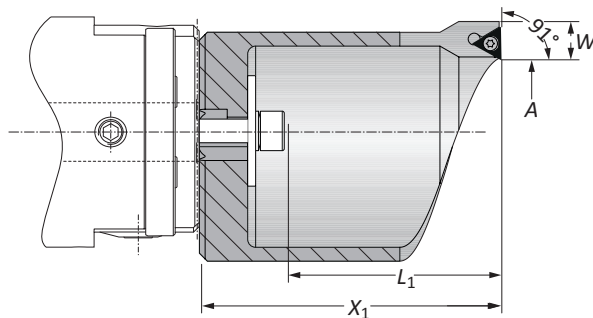
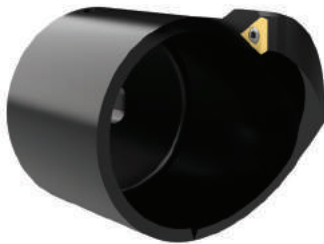

**Type B Insert Holders | Diameter Range: 1.142" - 2.598" (29.00 mm - 66.00 mm)**

	Boring Range		Insert Holder				Weight	Type	Insert Form	Part No.
	A	X <sub>1</sub>	L <sub>1</sub>	W						
i	1.142 - 1.732	2.952	2.126	0.377	0.661 (lbs)	B	20*	236083		
	1.693 - 2.598	3.956	3.110	0.377	0.882 (lbs)	B	20*	236084		
m	29.00 - 44.00	75.50	54.00	9.60	0.30 (kg)	B	20*	236083		
	43.00 - 66.00	100.50	79.00	9.60	0.40 (kg)	B	20*	236084		

**NOTE:** Clockwise and neutral execution

\*Not suitable for indexable inserts with a radius of 0.031" (0.80 mm)

### Clamping Pieces for Outside Turning Insert Holders

	Insert Holder Type	Boring Range	Service Key	Complete Part No.
m	A	4.00 - 30.00	s5	236088
	B	29.00 - 66.00	s5	236089

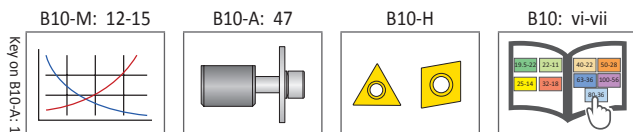
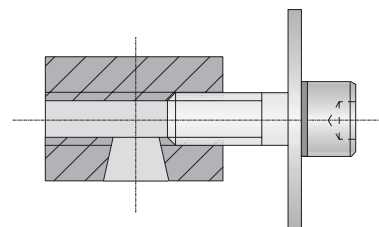

Key on B10-A: 1

i = Imperial (in)  
m = Metric (mm)  
Inserts sold separately

A  
B  
C  
D  
E  
F  
G  
H  
I  
J  
K  
L  
M  
INDEX

## Outside Turning Serrated Slides | Insert Holders

Diameter Range: 0.078" - 4.488" (2.00 mm - 114.00 mm)

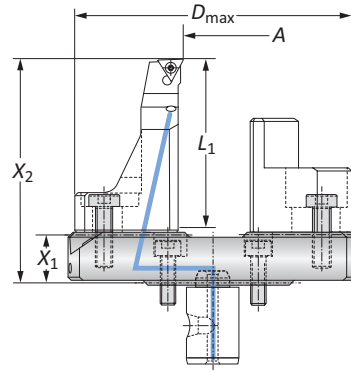

### Outside Turning Serrated Slides

	Boring Range		Serrated Slide			Weight	Part No.
	A	X <sub>1</sub>	X <sub>2</sub>	L <sub>1</sub>	D <sub>max</sub>		
i	0.078 - 1.181	0.630	2.874	2.165	3.396	0.771 (lbs)	501064
	1.181 - 2.283	0.630	2.874	2.165	5.078	0.970 (lbs)	501065
	2.283 - 3.386	0.866	3.110	2.165	6.181	1.322 (lbs)	501066
	3.386 - 4.488	0.866	3.110	2.165	7.283	1.609 (lbs)	501067
m	2.00 - 30.00	16.00	73.00	55.00	101.00	0.35 (kg)	501064
	30.00 - 58.00	16.00	73.00	55.00	129.00	0.44 (kg)	501065
	58.00 - 86.00	22.00	79.00	55.00	157.00	0.60 (kg)	501066
	86.00 - 114.00	22.00	79.00	55.00	185.00	0.73 (kg)	501067

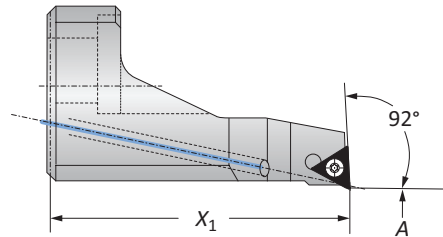

### Insert Holders

	Outside Turning Range	Insert Holder	Weight	Insert Form	Part No.
	A	X <sub>1</sub>			
i	0.079 - 4.488	2.244	0.331 (lbs)	20	502082
m	2.00 - 114.00	57.00	0.15 (kg)	20	502082

NOTE: clockwise and neutral execution

### Counterweights

	Counterweight		Part No.
	X <sub>1</sub>	Weight	
i	1.486	0.350 (lbs)	502183
m	37.75	0.16 (kg)	502183

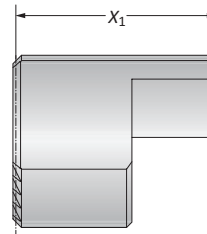

### Coolant Delivery Sections

	Coolant Delivery Section		Part No.
	X <sub>1</sub>	Weight	
i	1.004	0.022 (lbs)	450137
m	25.50	0.01 (kg)	450137

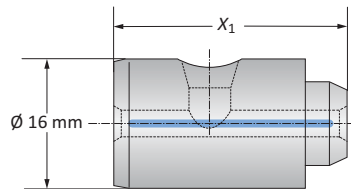

B10-M: 12-15

B10-A: 47

B10-H

B10: vi-vii

Key on B10-A: 1

i = Imperial (in)  
m = Metric (mm)

Inserts sold separately

## Accessories

### Clamping Elements

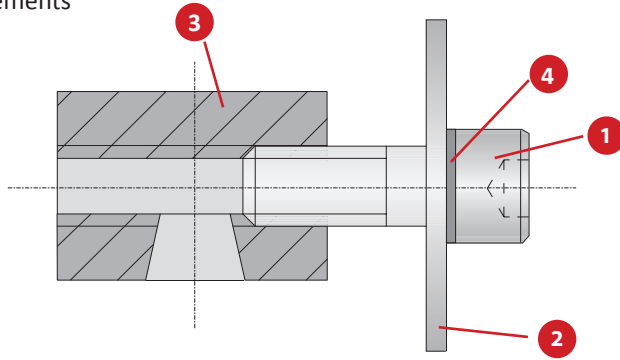

#### Clamping Elements for Insert Holders

	1	2	3	4		
Boring Range	Cap Screw	Hex Size	Washer	Clamping Nut	Locking Washer	Complete Part No.
<b>m</b> 4.00 - 30.00	070153	s5	315155	236120	215254	236088
29.00 - 66.00	070153	s5	315156	236120	215254	236089

#### Clamping Elements for Serrated Tool Body

1	2
Cap Screw	Clamping Piece
027154	145184

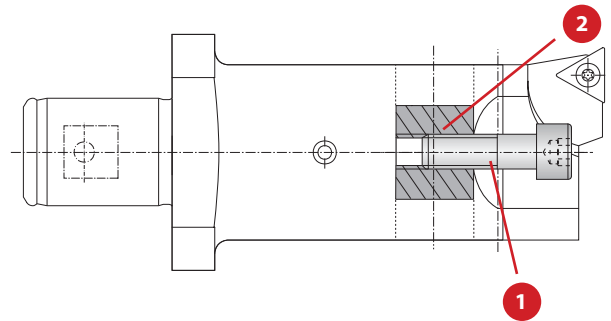

#### Thread Pin

1
Service Key
S3 / A
Part No.
415244

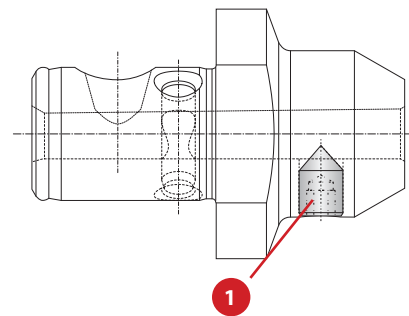

**i** = Imperial (in)  
**m** = Metric (mm)

A  
B  
C  
D  
E  
F  
G  
H  
I  
J  
K  
L  
M  
INDEX

## Kit Components

Form 101 | Diameter Range: 0.236" - 5.039" (6.00 mm - 128.00 mm)

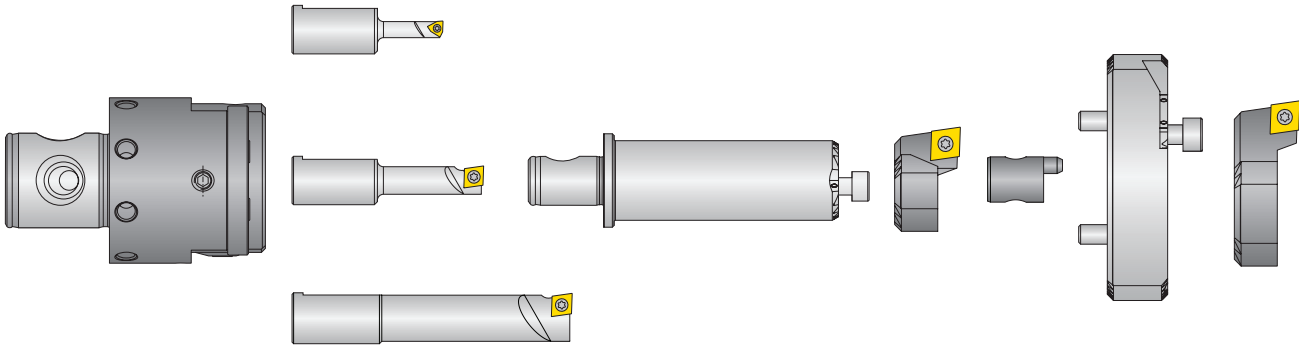

Diameter Range: 0.236" - 5.039" (6.00 mm - 128.00 mm)

Kit Components									
Boring Head	Boring Bars		Insert Holders		Serrated Tool Body	Serrated Slide	Coolant Delivery Section	Service Keys	Kit No.
	Boring Range	Part No.	Boring Range	Part No.					
i	0.236 - 0.394	450026 (Form 211)	0.945 - 1.575	450022	450021	450024	450125	003195 (s4) 515451 (T6) 515452 (T8)	104088
	0.394 - 0.630	450027 (Form 101)	1.575 - 2.559	450023					
	0.630 - 0.945	450028 (Form 101)							
m	6.00 - 10.00	450026 (Form 211)	24.00 - 40.00	450022	450021	450024	450125	003195 (s4) 515451 (T6) 515452 (T8)	103088
	10.00 - 16.00	450027 (Form 101)	40.00 - 65.00	450023					
	16.00 - 24.00	450028 (Form 101)							

NOTE: Inserts sold separately



B10-M: 12-15

B10-H

B10: vi-vii

Key on B10-A: 1

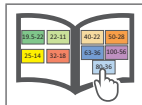
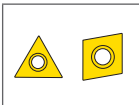
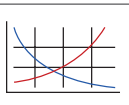

i = Imperial (in)  
m = Metric (mm)

Inserts sold separately

**IMPORTANT:** Max spindle speed refers to maximum possible speed for an individual boring head and is not a recommended parameter. Refer to page B10-M: 12 for recommended application-specific parameters. Factory technical assistance is available for your specific applications through our Application Engineering department.  
ext: 7611 | email: [appeng@alliedmachine.com](mailto:appeng@alliedmachine.com)

## Kit Components

Form 20 | Diameter Range: 0.236" - 5.039" (6.00 mm - 128.00 mm)

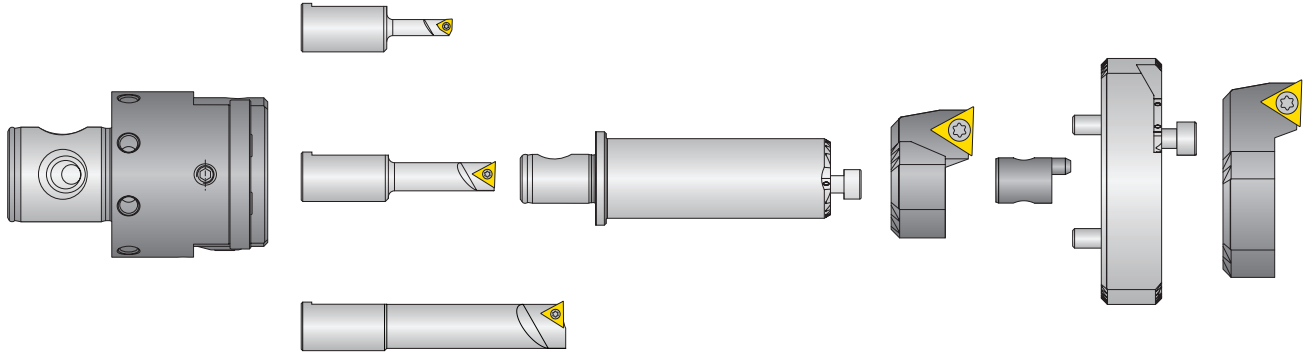

Diameter Range: 0.236" - 5.039" (6.00 mm - 128.00 mm)

Kit Components										
	Boring Head	Boring Bars		Insert Holders		Serrated Tool Body	Serrated Slide	Coolant Delivery Section	Service Keys	Kit No.
		Boring Range	Part No.	Boring Range	Part No.					
i	451001	0.236 - 0.394	450026 (Form 211)	0.945 - 1.575	450040	450021	450024	450125	003195 (s4)	104089
		0.394 - 0.630	450038 (Form 20)	1.575 - 2.559	450041				515451 (T6)	
		0.630 - 0.945	450039 (Form 20)						515453 (T7)	
m	450001	6.00 - 10.00	450026 (Form 211)	24.00 - 40.00	450040	450021	450024	450125	003195 (s4)	103089
		10.00 - 16.00	450038 (Form 20)	40.00 - 65.00	450041				515451 (T6)	
		16.00 - 24.00	450039 (Form 20)						515453 (T7)	

NOTE: Inserts sold separately



B10-M: 12-15

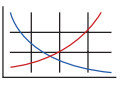

Key on B10-A-1

B10-H

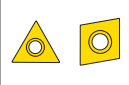

B10: vi-vii

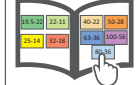

i = Imperial (in)  
m = Metric (mm)  
Inserts sold separately

**IMPORTANT:** Max spindle speed refers to maximum possible speed for an individual boring head and is not a recommended parameter. Refer to page B10-M: 12 for recommended application-specific parameters. Factory technical assistance is available for your specific applications through our Application Engineering department.  
ext: 7611 | email: [appeng@alliedmachine.com](mailto:appeng@alliedmachine.com)

A  
B  
C  
D  
E  
F  
G  
H  
I  
J  
K  
L  
M  
INDEX



# Digital 511 (510) Product Overview



## Digital 511 (510) VERSATILE FINE BORING

Improve your boring job with the Digital 511 (510) boring head.

The Wohlhaupter® Digital 511 (510) boring head offers precision, quality, and efficiency. Our integrated digital display makes the 511 (510) the smallest precision boring tool available and allows for easy optoelectronic adjusting.

Experience *precision boring* for yourself.

- Diameter range: 0.016" - 1.339" (0.40 mm - 12.00 mm)
- Easy-to-read digital display
- Coolant through
- External counterweight for balancing
- Protected against coolant and dust according to IP65
- Fine adjustments of 0.0001" (0.002 mm)
- Ideal for CAT40, BT30, HSK40
- 511001 (510001) max spindle speed: 35,000 RPM
- 511021 max spindle speed: 30,000 RPM



**NOTE:** Imperial item pictured

**NOTE:** Adjustment accuracy of 0.0001" or 0.002 mm on diameter

**IMPORTANT:** Max spindle speed refers to maximum possible speed for an individual boring head and is not a recommended parameter. Refer to page B10-M: 12 for recommended application-specific parameters. Factory technical assistance is available for your specific applications through our Application Engineering department.  
ext: 7611 | email: [appeng@alliedmachine.com](mailto:appeng@alliedmachine.com)

# DIGITAL



**NOTE:** Imperial item pictured  
**NOTE:** Adjustment accuracy of 0.0001" or 0.002 mm on diameter

**Digital 511001 (510001) Boring Head**  
Ø 0.016" - 0.472" (0.40 mm - 12.00 mm)

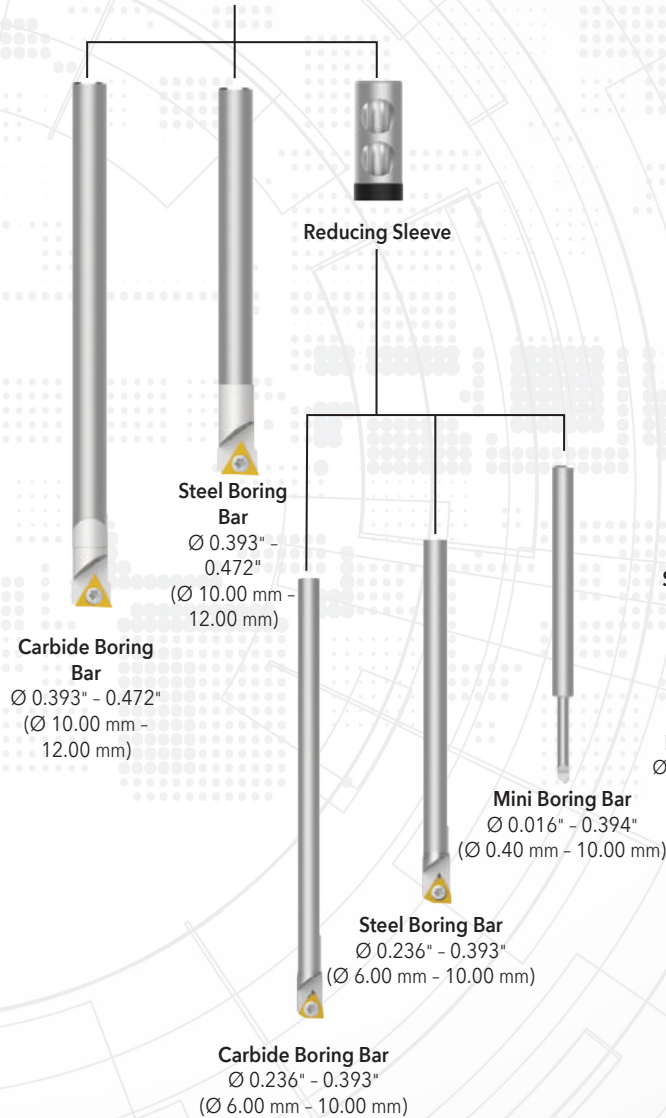

**NOTE:** Imperial item pictured  
**NOTE:** Adjustment accuracy of 0.0001" or 0.002 mm on diameter

**Digital 511021 Boring Head**  
Ø 0.016" - 1.339"

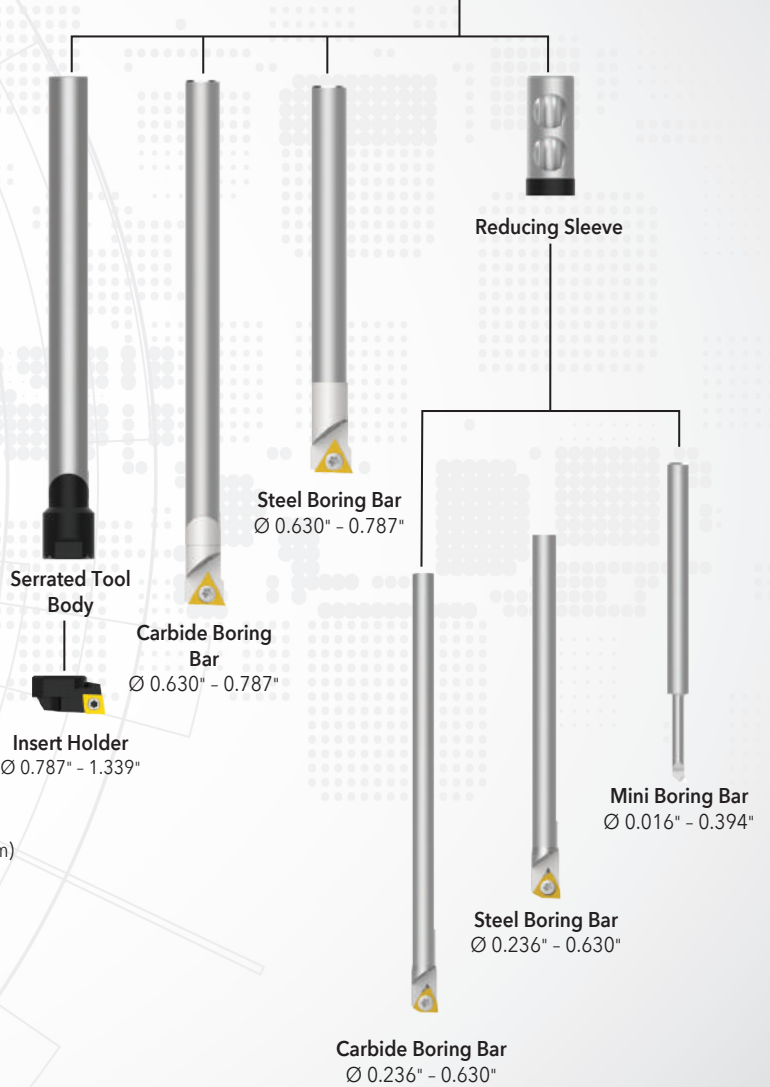

## OPERATION **VERSATILITY**

from **0.016"** to **1.339"** (0.40 mm to 12.00 mm)

## Boring Heads

Diameter Range: 0.016" - 1.339" (0.40 mm - 12.00 mm)

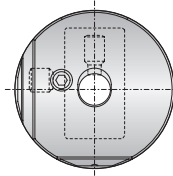

Fine Radial Stroke  
+1.1 mm  
-0.1 mm

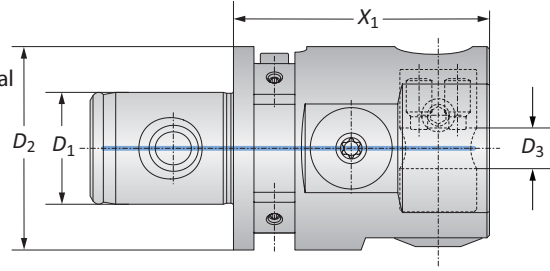

**NOTE:** Imperial item pictured

**NOTE:** Adjustment accuracy of 0.0001" or 0.002 mm on diameter

### Boring Heads

	MVS Connection	Boring Range	Boring Head		Weight	Part No.
	$D_2$   $D_1$		$D_3$	$X_1$		
<b>i</b>	40 - 22	0.016 - 0.472	0.315	1.969	0.926 (lbs)	<b>511001</b>
	50 - 28	0.016 - 1.339	0.551	2.165	1.565 (lbs)	<b>511021</b>
<b>m</b>	40 - 22	0.40 - 12.00	8.00	50.00	0.42 (kg)	<b>510001</b>

B10-M: 12-15

B10-F

B10: vi-vii

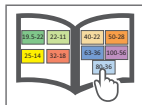
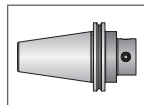
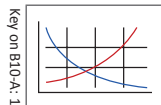

Key on B10-A: 1

**i** = Imperial (in)  
**m** = Metric (mm)

**IMPORTANT:** Max spindle speed refers to maximum possible speed for an individual boring head and is not a recommended parameter. Refer to page B10-M: 12 for recommended application-specific parameters. Factory technical assistance is available for your specific applications through our Application Engineering department.  
ext: 7611 | email: [appeng@alliedmachine.com](mailto:appeng@alliedmachine.com)

## Mini Boring Bars

Diameter Range: 0.016" - 0.197" (0.40 mm - 5.00 mm)

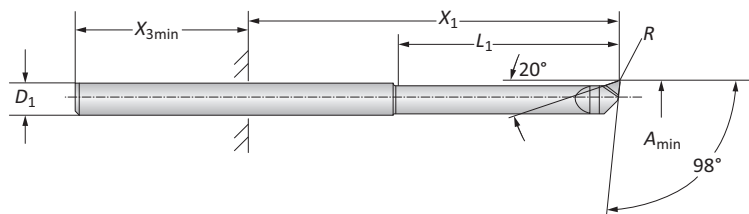

### Mini Boring Bars

Boring Head	Boring Range	Boring Bar					Part No.	
		$A_{min}$	$D_1$	$X_1$	$X_{3\ min}$	$L_1$		$R$
i	511001	0.016	0.157*	0.118 - 1.042	0.630	0.079	0.001	081401WHC126
		0.024	0.157*	0.157 - 1.063	0.630	0.118	0.002	081402WHC126
		0.031	0.157*	0.197 - 1.102	0.630	0.157	0.002	081403WHC126
		0.039	0.157*	0.236 - 1.142	0.630	0.197	0.002	081404WHC126
		0.059	0.157*	0.335 - 1.220	0.630	0.295	0.002	081405WHC126
		0.079	0.157*	0.433 - 1.339	0.630	0.394	0.002	081406WHC126
		0.098	0.157*	0.531 - 1.437	0.630	0.492	0.002	081407WHC126
		0.110	0.157*	0.591 - 1.496	0.630	0.551	0.003	081408WHC126
	511021	0.016	0.157*	0.118 - 0.669	0.980	0.079	0.001	081401WHC126
		0.024	0.157*	0.157 - 0.709	0.980	0.118	0.002	081402WHC126
		0.031	0.157*	0.197 - 0.748	0.980	0.157	0.002	081403WHC126
		0.039	0.157*	0.236 - 0.787	0.980	0.197	0.002	081404WHC126
		0.059	0.157*	0.335 - 0.886	0.980	0.295	0.002	081405WHC126
		0.079	0.157*	0.433 - 0.984	0.980	0.394	0.002	081406WHC126
m	510001	0.40	4.00*	3.00 - 26.00	16.00	2.00	0.03	081401WHC126
		0.60	4.00*	4.00 - 27.00	16.00	3.00	0.04	081402WHC126
		0.80	4.00*	5.00 - 28.00	16.00	4.00	0.04	081403WHC126
		1.00	4.00*	6.00 - 29.00	16.00	5.00	0.05	081404WHC126
		1.50	4.00*	8.50 - 31.50	16.00	7.50	0.05	081405WHC126
		2.00	4.00*	11.00 - 34.00	16.00	10.00	0.05	081406WHC126
		2.50	4.00*	13.50 - 36.50	16.00	12.50	0.05	081407WHC126
		2.80	4.00*	15.00 - 38.00	16.00	14.00	0.07	081408WHC126

\*Fixture-through reducing sleeve required (B10-A: 58)

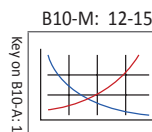

i = Imperial (in)  
m = Metric (mm)

A  
B  
C  
D  
E  
F  
G  
H  
I  
J  
K  
L  
M  
INDEX

### Mini Boring Bars

WHC05 | WHW04 | WBN150 | Diameter Range: 0.118" - 0.394" (3.00 mm - 10.00 mm)

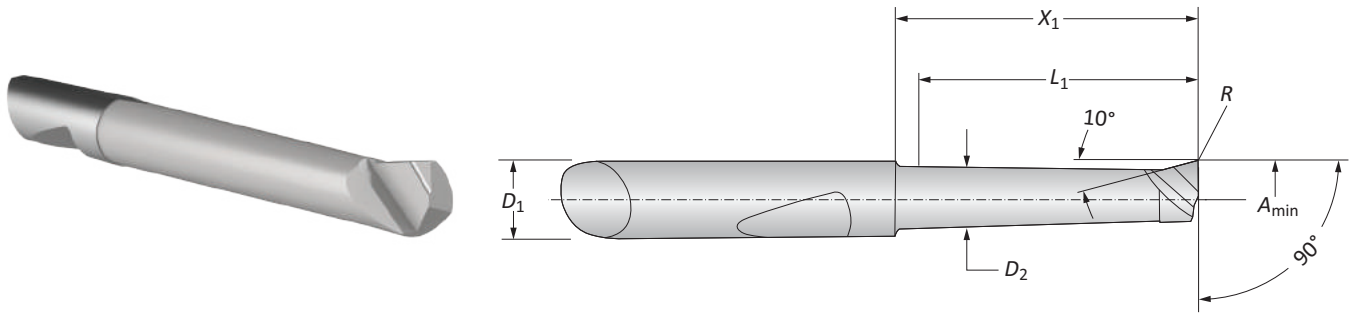

Boring Range	Boring Bar						Part No.		
	$A_{min}$	$D_1$	$D_2$	$X_1$	$L_1$	$R$	Coated Carbide	Uncoated Carbide	CBN
	0.118	0.236*	0.102	0.452	0.393	0.003	081306WHC05	-	081322WBN150
	0.118	0.236*	0.102	0.649	0.590	0.003	081307WHC05	081307WHW04	-
	0.157	0.236*	0.141	0.472	0.393	0.007	081308WHC05	-	081317WBN150
	0.157	0.236*	0.141	0.669	0.590	0.007	081309WHC05	-	081341WBN150
	0.157	0.236*	0.141	0.866	0.787	0.007	081310WHC05	081310WHW04	-
	0.196	0.236*	0.181	0.472	0.393	0.007	081311WHC05	-	081318WBN150
<b>i</b>	0.196	0.236*	0.181	0.866	0.787	0.007	081312WHC05	-	081319WBN150
	0.196	0.236*	0.181	1.259	1.181	0.007	081313WHC05	081313WHW04	-
	0.236	0.236*	0.220	0.866	0.787	0.007	081314WHC05	-	081320WBN150
	0.236	0.236*	0.220	1.259	1.181	0.007	081315WHC05	-	081321WBN150
	0.236	0.236*	0.220	1.653	1.574	0.007	081316WHC05	081316WHW04	-
	0.315	0.315**	0.229	0.984	0.905	0.007	081323WHC05	-	-
	0.315	0.315**	0.229	1.968	1.889	0.007	081324WHC05	-	-
	3.00	6.00*	2.60	11.50	10.00	0.10	081306WHC05	-	081322WBN150
	3.00	6.00*	2.60	16.50	15.00	0.10	081307WHC05	081307WHW04	-
	4.00	6.00*	3.60	12.00	10.00	0.20	081308WHC05	-	081317WBN150
	4.00	6.00*	3.60	17.00	15.00	0.20	081309WHC05	-	081341WBN150
	4.00	6.00*	3.60	22.00	20.00	0.20	081310WHC05	081310WHW04	-
	5.00	6.00*	4.60	12.00	10.00	0.20	081311WHC05	-	081318WBN150
<b>m</b>	5.00	6.00*	4.60	22.00	20.00	0.20	081312WHC05	-	081319WBN150
	5.00	6.00*	4.60	32.00	30.00	0.20	081313WHC05	081313WHW04	-
	6.00	6.00*	5.60	22.00	20.00	0.20	081314WHC05	-	081320WBN150
	6.00	6.00*	5.60	32.00	30.00	0.20	081315WHC05	-	081321WBN150
	6.00	6.00*	5.60	42.00	40.00	0.20	081316WHC05	081316WHW04	-
	8.00	8.00**	7.60	25.00	23.00	0.20	081323WHC05	-	-
	8.00	8.00**	7.60	50.00	48.00	0.20	081324WHC05	-	-

\*Fixture-through reducing sleeve required (B10-A: 58)

\*\*For 511021 fixture-through reducing sleeve required

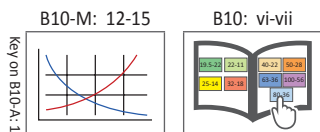

**i** = Imperial (in)  
**m** = Metric (mm)



## Boring Bars

Steel | Diameter Range: 0.236" - 0.787" (6.00 mm - 12.00 mm)



Form 101

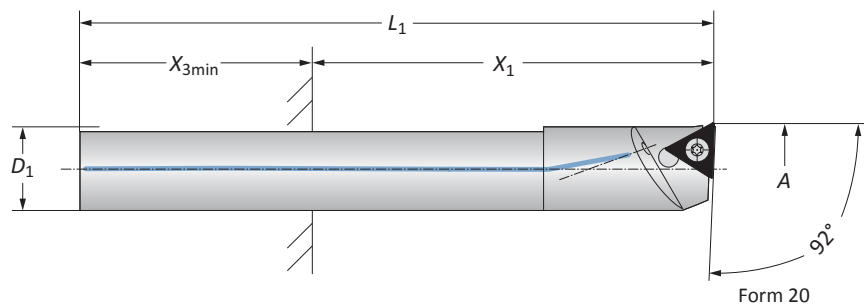

Form 20

Boring Head	Boring Range	Boring Bar				Weight	Part No.				
		A	D <sub>1</sub>	X <sub>1</sub>	X <sub>3 min</sub>		L <sub>1</sub>	Insert Form	Boring Bar	Insert Form	Boring Bar
i	511001	0.236 - 0.315	0.197*	0.492 - 0.984	0.63	2.756	0.022 (lbs)	211**	514032	-	-
		0.315 - 0.394	0.276*	0.689 - 1.378	0.63	3.189	0.044 (lbs)	211**	514033	-	-
		0.394 - 0.472	0.315	0.787 - 1.575	0.748	3.346	0.066 (lbs)	101	514003	20**	514004
i	511021	0.236 - 0.315	0.197*	0.492 - 0.984	0.984	2.756	0.022 (lbs)	211**	514032	-	-
		0.315 - 0.394	0.276*	0.689 - 1.378	0.984	3.189	0.044 (lbs)	211**	514033	-	-
		0.394 - 0.472	0.315*	0.787 - 1.575	0.984	3.346	0.066 (lbs)	101	514003	20**	514004
		0.472 - 0.551	0.394*	0.984 - 1.969	0.984	3.937	0.110 (lbs)	101	514005	20**	514006
		0.551 - 0.630	0.472*	1.181 - 2.362	1.181	4.488	0.198 (lbs)	101	514007	20**	514008
		0.630 - 0.709	0.551	2.205 - 2.756	1.181	4.764	0.287 (lbs)	101	514009	20**	514010
m	510001	6.00 - 8.00	5.00*	12.50 - 25.00	16.00	70.00	0.01 (kg)	211**	514032	-	-
		8.00 - 10.00	7.00*	17.50 - 35.00	16.00	81.00	0.02 (kg)	211**	514033	-	-
		10.00 - 12.00	8.00	20.00 - 40.00	19.00	85.00	0.03 (kg)	101	514003	20**	514004

\*Fixture-through reducing sleeve required (B10-A: 58)

\*\*Not suitable for indexable inserts with a radius of 0.031" (0.8 mm)

B10-M: 12-15

B10-A: 59

B10-H

B10: vi-vii

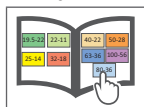
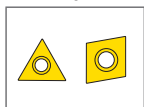
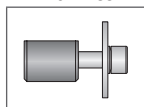
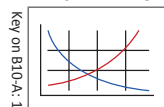

i = Imperial (in)  
m = Metric (mm)  
Inserts sold separately

A  
B  
C  
D  
E  
F  
G  
H  
I  
J  
K  
L  
M  
INDEX

## Boring Bars

Carbide | Diameter Range: 0.236" - 0.787" (6.00 mm - 12.00 mm)



Form 101

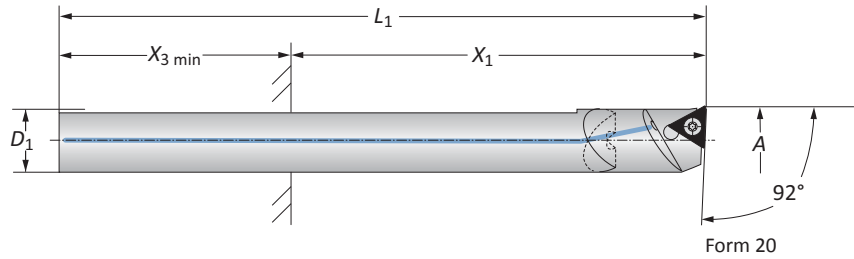

Form 20

Boring Head	Boring Range	Boring Bar					Weight	Part No.			
		A	D <sub>1</sub>	X <sub>1</sub>	X <sub>3 min</sub>	L <sub>1</sub>		Insert Form	Boring Bar	Insert Form	Boring Bar
511001	0.236 - 0.315	0.197*	0.492 - 1.575	0.63	3.543	0.044 (lbs)	211**	514034	-	-	
	0.315 - 0.394	0.276*	0.827 - 2.205	0.63	4.291	0.110 (lbs)	211**	514035	-	-	
	0.394 - 0.472	0.315	0.866 - 2.520	0.748	4.606	0.154 (lbs)	101	514015	20**	514016	
511021	0.236 - 0.315	0.197*	0.492 - 1.575	0.984	3.543	0.044 (lbs)	211**	514034	-	-	
	0.315 - 0.394	0.276*	0.827 - 2.205	0.984	4.291	0.110 (lbs)	211**	514035	-	-	
	0.394 - 0.472	0.315*	0.866 - 2.520	0.984	4.606	0.154 (lbs)	101	514015	20**	514016	
	0.472 - 0.551	0.394*	2.008 - 3.150	1.181	5.512	0.287 (lbs)	101	514017	20**	514018	
	0.551 - 0.630	0.472*	2.677 - 3.780	1.181	6.378	0.485 (lbs)	101	514019	20**	514020	
	0.630 - 0.709	0.551	3.031 - 4.409	1.181	5.591	0.573 (lbs)	101	514021	20**	514022	
	0.630 - 0.709	0.551	4.409 - 5.787	1.181	6.969	0.728 (lbs)	101	514023	20**	514024	
	0.709 - 0.787	0.551	3.031 - 4.409	1.181	5.591	0.573 (lbs)	101	514025	20**	514026	
0.709 - 0.787	0.551	4.409 - 5.787	1.181	6.969	0.728 (lbs)	101	514027	20**	514028		
510001	6.00 - 8.00	5.00*	12.50 - 40.00	16.00	90.00	0.02 (kg)	211**	514034	-	-	
	8.00 - 10.00	7.00*	21.00 - 56.00	16.00	109.00	0.05 (kg)	211**	514035	-	-	
	10.00 - 12.00	8.00	22.00 - 64.00	19.00	117.00	0.07 (kg)	101	514015	20**	514016	

\*Fixture-through reducing sleeve required (B10-A: 58)

\*\*Not suitable for indexable inserts with a radius of 0.031" (0.80 mm)

B10-M: 12-15

B10-A: 59

B10-H

B10: vi-vii

Key on B10-A: 1

i = Imperial (in)  
m = Metric (mm)  
Inserts sold separately

A  
B  
C  
D  
E  
F  
G  
H  
I  
J  
K  
L  
M  
INDEX

## Serrated Tool Bodies | Insert Holders

Diameter Range: 0.787" - 1.339"

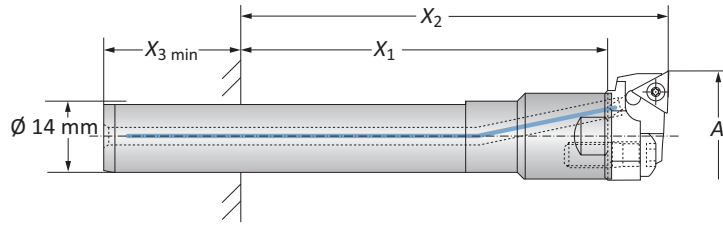

### Serrated Tool Bodies

	Substrate	Boring Range	Serrated Tool Body			Weight	Part No.
		A	X <sub>1</sub>	X <sub>2</sub>	X <sub>3 min</sub>		
i	Steel	0.787 - 1.339	1.457 - 2.835	1.929 - 3.307	1.181	0.287 (lbs)	514029
	Carbide	0.787 - 1.339	2.550 - 3.937	3.031 - 4.409	1.181	0.551 (lbs)	514030
	Carbide	0.787 - 1.339	3.937 - 5.315	4.409 - 5.787	1.181	0.728 (lbs)	514031



Form 101

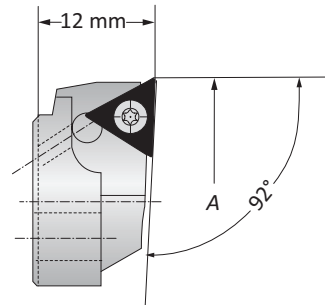



Form 20

### Insert Holders

	Boring Range		Insert Form	Part No.	Insert Form	Part No.
	A	Weight				
i	0.787 - 0.866	0.022 (lbs)	101	502052	20*	502046
	0.866 - 0.945	0.022 (lbs)	101	502053	20*	502047
	0.945 - 1.024	0.022 (lbs)	101	502054	20*	502048
	1.024 - 1.102	0.022 (lbs)	101	502055	20*	502049
	1.102 - 1.181	0.022 (lbs)	101	502056	20*	502050
	1.181 - 1.260	0.022 (lbs)	101	502057	20*	502051

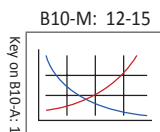
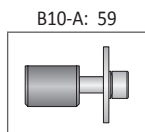
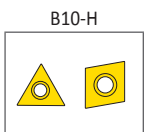
\*Not suitable for indexable inserts with a radius of 0.031" (0.80 mm)

i = Imperial (in)  
m = Metric (mm)  
Inserts sold separately

A  
B  
C  
D  
E  
F  
G  
H  
I  
J  
K  
L  
M  
INDEX

## Reducing Sleeves

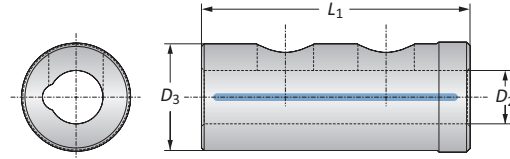

### Metric Reducing Sleeves

Reducing Sleeve				Part No.
$D_3$	$D_2$	$L_1$		
8.00	4.00	20.00	514201	
8.00	5.00	20.00	514202	
8.00	6.00	20.00	514210	
8.00	7.00	20.00	514203	
14.00	4.00	32.00	514204	
14.00	5.00	32.00	514205	
14.00	6.00	32.00	514211	
14.00	7.00	32.00	514206	
14.00	8.00	32.00	514207	
14.00	10.00	32.00	514208	
14.00	12.00	32.00	514209	

## Boring Head Accessories

No.	Part	Insert Form	Size	Part No.	
				511001 (510001)	511021
1	Clamping screw	-	-	115985	315943
2	Thread pin for tool clamping	-	-	070333	115181
3	Sealing ring for battery cover	-	-	415895	415895
4	Battery*	-	-	415896	415896
5	Battery cover with sealing ring	-	-	501016	501016
6	Thread pin	-	-	510114	510114
7	Insert screws	Form 20	T7	115535	115535
		Form 101	T8	115676	115676
		Form 211	T6	515286	515286
8	Clamping Screw	-	T25	-	415112
9	Hex wrench	-	s2	215473	215473
10	Hex wrench	-	s2.5	415577	415577
		-	s3.0	415578	415578
		-	s4.0	115576	115576
11	Torx driver	-	T6	115537	115537
		-	T7	115591	115591
		-	T8	115590	115590
		-	T20	215150	215150
12	Torx screw-driver	Form 211	T6	415507	415507
		Form 20	T7	415508	415508
		Form 101	T8	415514	415514

\*Always change two batteries  
**NOTE:** Please use VARTA batteries

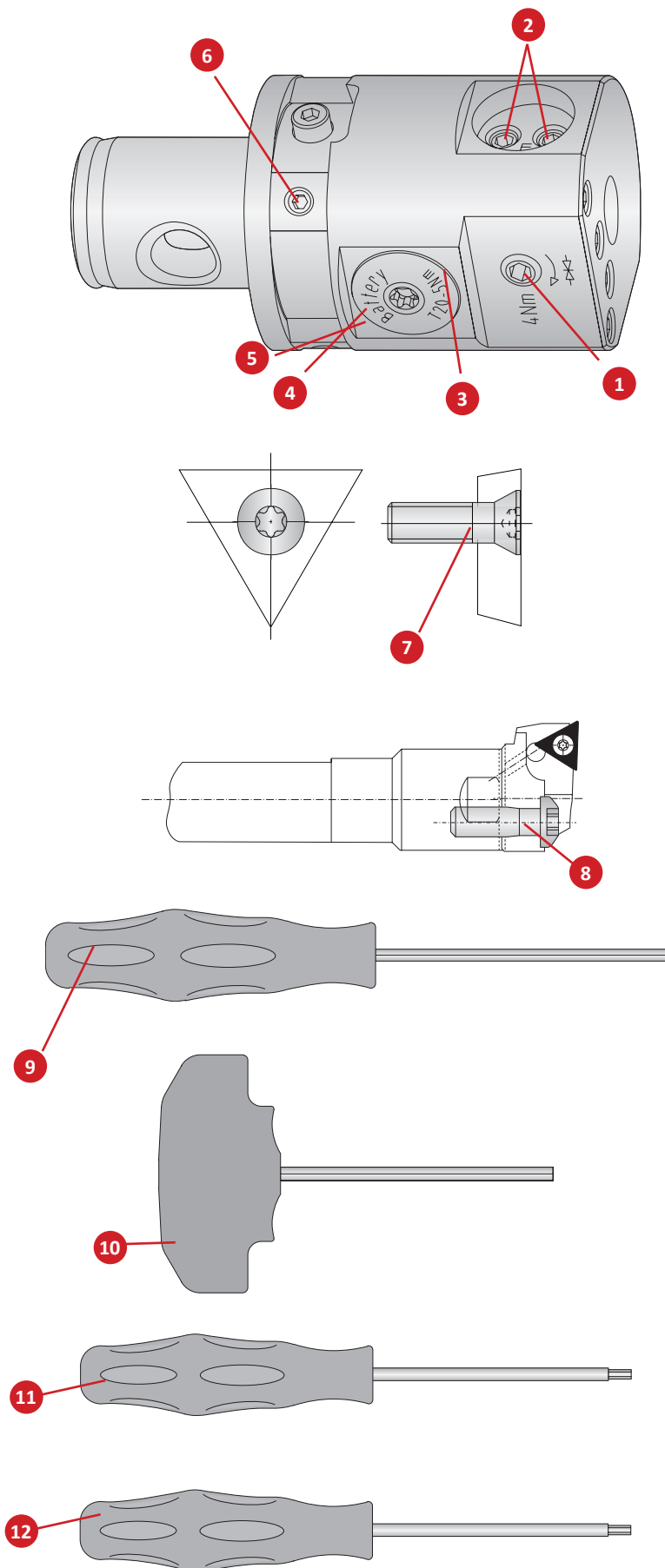

A  
B  
C  
D  
E  
F  
G  
H  
I  
J  
K  
L  
M  
INDEX



# DigiBore Product Overview



## DigiBore VERSATILE FINE BORING

### Advanced versatile technology.

The Wohlhaupter® DigiBore boring head provides internal balancing, which makes this tool the stress-free choice to meet your required surface finish. Its digital display allows for quick and accurate diameter corrections at the machine.

Engineered with the *future in mind*.

- Diameter range: 0.118" - 8.189" (3.00 mm - 208.00 mm)
- Offers outside turning capabilities: 0.157" - 4.488" (4.00 mm - 114.00 mm)
- Digital readout for simple 0.0001" (0.002 mm) diameter adjustments
- Ease the stress of working on different day-to-day projects with boring kits
- Automatic internal balancing improves surface finish, tool life, and accuracy
- Max spindle speed: 16,000 RPM
- Max coolant pressure: 580 PSI (40 bar)



**NOTE:** Imperial items pictured

**NOTE:** Adjustment accuracy of 0.0001" or 0.002 mm on diameter

**IMPORTANT:** Max spindle speed refers to maximum possible speed for an individual boring head and is not a recommended parameter. Refer to page B10-M: 12 for recommended application-specific parameters. Factory technical assistance is available for your specific applications through our Application Engineering department.  
ext: 7611 | email: [appeng@alliedmachine.com](mailto:appeng@alliedmachine.com)



DigiBore Head

NOTE: Imperial items pictured  
NOTE: Adjustment accuracy of 0.0001" or 0.002 mm on diameter

# DIGI BORE

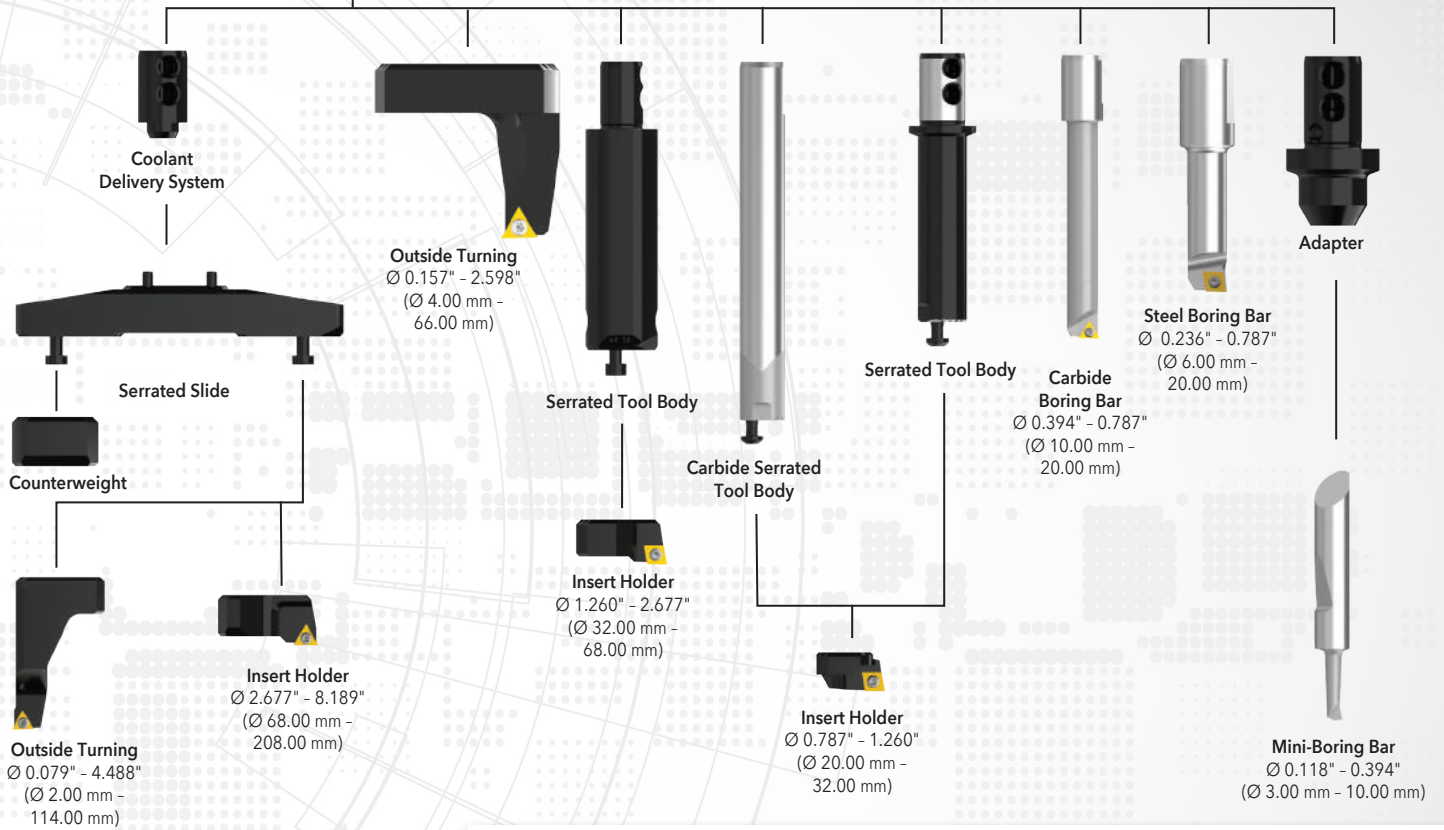

## OPERATION **VERSATILITY**

from **0.118"** to **8.189"** (3.00 mm to 208.00 mm)  
*plus outside turning*



NOTE: Imperial items pictured  
NOTE: Adjustment accuracy of 0.0001" or 0.002 mm on diameter

## Boring Heads

Diameter Range: 0.118" - 8.189" (3.00 mm - 208.00 mm)

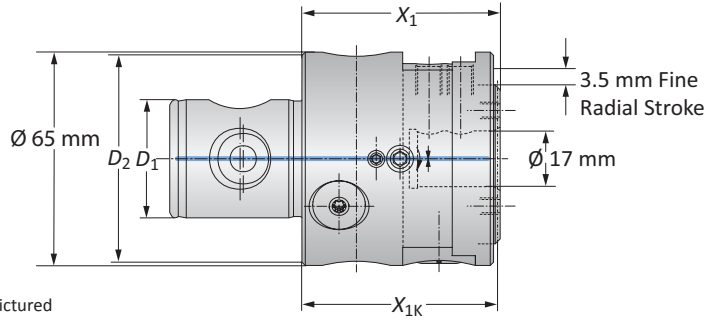

NOTE: Imperial items pictured  
NOTE: Adjustment accuracy of 0.0001" or 0.002 mm on diameter

### DigiBore Boring Heads

	MVS Connection		Boring Head		Weight	Part No.
	D <sub>2</sub>   D <sub>1</sub>	Boring Range	X <sub>1</sub>	X <sub>1K</sub>		
i	50 - 28	0.118 - 8.189	2.362	2.342	2.866 (lbs)	504003
	63 - 36	0.118 - 8.189	2.362	2.342	3.307 (lbs)	504001
m	50 - 28	3.00 - 208.00	60.00	59.50	1.30 (kg)	501005
	63 - 36	3.00 - 208.00	60.00	59.50	1.50 (kg)	501001

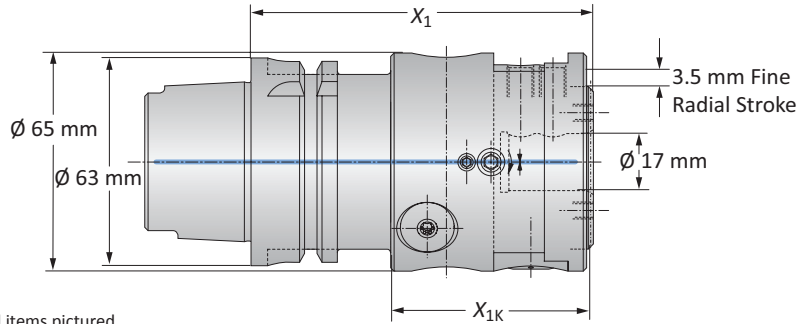

NOTE: Imperial items pictured  
NOTE: Adjustment accuracy of 0.0001" or 0.002 mm on diameter

### DigiBore Boring Heads

	Connection		Boring Head		Weight	Part No.
	Connection	Boring Range	X <sub>1</sub>	X <sub>1K</sub>		
i	HSK-A 63	0.118 - 8.189	4.015	2.342	4.630 (lbs)	504004
	PSC 63 (Polygon Shank)	0.118 - 8.189	4.015	2.342	4.630 (lbs)	504019
m	HSK-A 63	3.00 - 208.00	102.00	59.50	2.10 (kg)	501004
	PSC 63 (Polygon Shank)	3.00 - 208.00	102.00	59.50	2.10 (kg)	501019

Key on B10-A: 1

B10-M: 12-15

B10-F

B10: vi-vii

i = Imperial (in)  
m = Metric (mm)

**IMPORTANT:** Max spindle speed refers to maximum possible speed for an individual boring head and is not a recommended parameter. Refer to page B10-M: 12 for recommended application-specific parameters. Factory technical assistance is available for your specific applications through our Application Engineering department.  
ext: 7611 | email: [appeng@alliedmachine.com](mailto:appeng@alliedmachine.com)



## Mini Boring Bars

WHC05 | WHW04 | WBN150 | Diameter Range: 0.118" - 0.394" (3.00 mm - 10.00 mm)

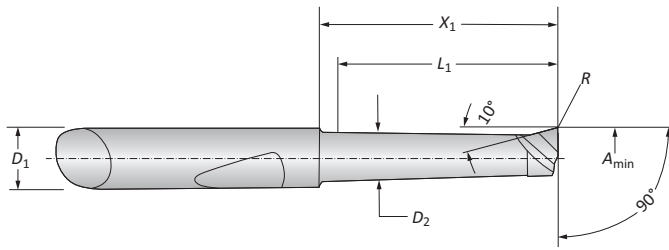

### Mini Boring Bars

	Boring Range		Boring Bar				Part No.		
	$A_{min}$	$D_1$	$D_2$	$X_1$	$L_1$	$R$	Coated Carbide	Uncoated Carbide	CBN
i	0.118	0.236	0.102	0.452	0.393	0.003	081306WHC05	-	081322WBN150
	0.118	0.236	0.102	0.649	0.590	0.003	081307WHC05	081307WHW04	-
	0.157	0.236	0.141	0.472	0.393	0.007	081308WHC05	-	081317WBN150
	0.157	0.236	0.141	0.669	0.590	0.007	081309WHC05	-	081341WBN150
	0.157	0.236	0.141	0.866	0.787	0.007	081310WHC05	081310WHW04	-
	0.196	0.236	0.181	0.472	0.393	0.007	081311WHC05	-	081318WBN150
	0.196	0.236	0.181	0.866	0.787	0.007	081312WHC05	-	081319WBN150
	0.196	0.236	0.181	1.259	1.181	0.007	081313WHC05	081313WHW04	-
	0.236	0.236	0.220	0.866	0.787	0.007	081314WHC05	-	081320WBN150
	0.236	0.236	0.220	1.259	1.181	0.007	081315WHC05	-	081321WBN150
	0.236	0.236	0.220	1.653	1.574	0.007	081316WHC05	081316WHW04	-
	0.315	0.315	0.229	0.984	0.905	0.007	081323WHC05	-	-
0.315	0.315	0.229	1.968	1.889	0.007	081324WHC05	-	-	
m	3.00	6.00	2.60	11.50	10.00	0.10	081306WHC05	-	081322WBN150
	3.00	6.00	2.60	16.50	15.00	0.10	081307WHC05	081307WHW04	-
	4.00	6.00	3.60	12.00	10.00	0.20	081308WHC05	-	081317WBN150
	4.00	6.00	3.60	17.00	15.00	0.20	081309WHC05	-	081341WBN150
	4.00	6.00	3.60	22.00	20.00	0.20	081310WHC05	081310WHW04	-
	5.00	6.00	4.60	12.00	10.00	0.20	081311WHC05	-	081318WBN150
	5.00	6.00	4.60	22.00	20.00	0.20	081312WHC05	-	081319WBN150
	5.00	6.00	4.60	32.00	30.00	0.20	081313WHC05	081313WHW04	-
	6.00	6.00	5.60	22.00	20.00	0.20	081314WHC05	-	081320WBN150
	6.00	6.00	5.60	32.00	30.00	0.20	081315WHC05	-	081321WBN150
	6.00	6.00	5.60	42.00	40.00	0.20	081316WHC05	081316WHW04	-
	8.00	8.00	7.60	25.00	23.00	0.20	081323WHC05	-	-
8.00	8.00	7.60	50.00	48.00	0.20	081324WHC05	-	-	



### Adapters

	Boring Range		Adapter				Weight	Part No.
	$A_{min}$	$X_1$	$L_1$	$D_3$	$D_5$			
m	3.00 - 8.00	22.50	14.00	6.00	20.00	0.04 (kg)	501050	
	8.00 - 10.00	22.50	14.00	8.00	22.00	0.04 (kg)	501051	

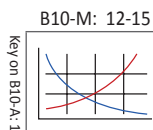
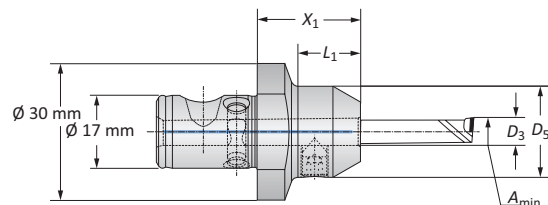

i = Imperial (in)  
m = Metric (mm)

A  
B  
C  
D  
E  
F  
G  
H  
I  
J  
K  
L  
M  
INDEX

## Boring Bars

Steel | Diameter Range: 0.236" - 0.787" (6.00 mm - 20.00 mm)



Form 101

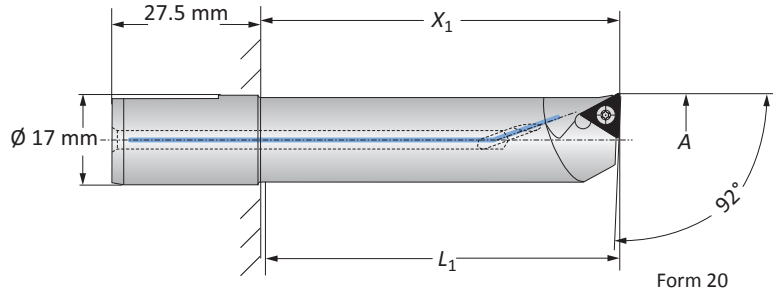

Boring Range	Boring Bar		Weight	Insert Form	Part No.	Insert Form	Part No.
	A	X <sub>1</sub>					
0.236 - 0.315	0.866	0.748	0.110 (lbs)	211*	502068	-	-
0.315 - 0.394	1.181	1.063	0.110 (lbs)	211*	502066	-	-
0.394 - 0.433	1.181	1.063	0.132 (lbs)	101	502012	20*	502001
0.433 - 0.472	1.181	1.063	0.132 (lbs)	101	502075	20*	502070
0.472 - 0.512	1.772	1.654	0.154 (lbs)	101	502013	20*	502002
0.512 - 0.551	1.772	1.654	0.176 (lbs)	101	502076	20*	502071
0.551 - 0.591	1.968	1.850	0.176 (lbs)	101	502014	20*	502003
0.591 - 0.630	1.968	1.850	0.198 (lbs)	101	502077	20*	502072
0.630 - 0.669	2.362	2.244	0.220 (lbs)	101	502015	20*	502004
0.669 - 0.709	2.362	2.244	0.265 (lbs)	101	502078	20*	502073
0.709 - 0.748	2.677	2.559	0.287 (lbs)	101	502016	20*	502005
0.748 - 0.787	2.677	2.559	0.309 (lbs)	101	502079	20*	502074
<hr/>							
6.00 - 8.00	22.00	19.00	0.05 (kg)	211*	502068	-	-
8.00 - 10.00	30.00	27.00	0.05 (kg)	211*	502066	-	-
10.00 - 11.00	30.00	27.00	0.06 (kg)	101	502012	20*	502001
11.00 - 12.00	30.00	27.00	0.06 (kg)	101	502075	20*	502070
12.00 - 13.00	45.00	42.00	0.07 (kg)	101	502013	20*	502002
13.00 - 14.00	45.00	42.00	0.08 (kg)	101	502076	20*	502071
14.00 - 15.00	50.00	47.00	0.08 (kg)	101	502014	20*	502003
15.00 - 16.00	50.00	47.00	0.09 (kg)	101	502077	20*	502072
16.00 - 17.00	60.00	57.00	0.10 (kg)	101	502015	20*	502004
17.00 - 18.00	60.00	57.00	0.12 (kg)	101	502078	20*	502073
18.00 - 19.00	68.00	65.00	0.13 (kg)	101	502016	20*	502005
19.00 - 20.00	68.00	65.00	0.14 (kg)	101	502079	20*	502074

\*Not suitable for indexable inserts with a radius of 0.031" (0.80 mm)

Key on B10-A: 1

B10-M: 12-15

B10-H

B10: vi-vii

i = Imperial (in)  
 m = Metric (mm)  
 Inserts sold separately

A  
B  
C  
D  
E  
F  
G  
H  
I  
J  
K  
L  
M  
INDEX



## Boring Bars

Carbide | Diameter Range: 0.394" - 0.787" (10.00 mm - 20.00 mm)



Form 101

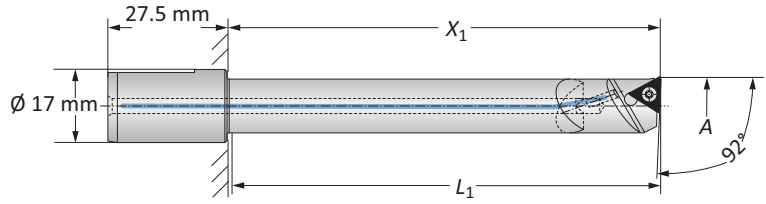

Form 20

	Boring Range		Boring Bar		Weight	Insert Form	Part No.	Insert Form	Part No.
	A	X <sub>1</sub>	L <sub>1</sub>						
<b>i</b>	0.394 - 0.472	2.165	2.047	0.265 (lbs)	101	502093	20*	502088	
	0.394 - 0.472	2.756	2.638	0.309 (lbs)	101	502034	20*	502023	
	0.472 - 0.551	2.559	2.441	0.287 (lbs)	101	502094	20*	502089	
	0.472 - 0.551	3.346	3.228	0.375 (lbs)	101	502035	20*	502024	
	0.551 - 0.630	2.953	2.835	0.375 (lbs)	101	502095	20*	502090	
	0.551 - 0.630	3.543	3.425	0.485 (lbs)	101	502036	20*	502025	
	0.630 - 0.709	3.346	3.228	0.573 (lbs)	101	502096	20*	502091	
	0.630 - 0.709	4.331	4.213	0.706 (lbs)	101	502037	20*	502026	
	0.709 - 0.787	3.740	3.622	0.617 (lbs)	101	502097	20*	502092	
0.709 - 0.787	4.724	4.606	0.882 (lbs)	101	502038	20*	502027		
<b>m</b>	10.00 - 12.00	55.00	52.00	0.12 (kg)	101	502093	20*	502088	
	10.00 - 12.00	70.00	67.00	0.14 (kg)	101	502034	20*	502023	
	12.00 - 14.00	65.00	62.00	0.13 (kg)	101	502094	20*	502089	
	12.00 - 14.00	85.00	82.00	0.18 (kg)	101	502035	20*	502024	
	14.00 - 16.00	75.00	72.00	0.17 (kg)	101	502095	20*	502090	
	14.00 - 16.00	90.00	87.00	0.22 (kg)	101	502036	20*	502025	
	16.00 - 18.00	85.00	82.00	0.26 (kg)	101	502096	20*	502091	
	16.00 - 18.00	110.00	107.00	0.32 (kg)	101	502037	20*	502026	
	18.00 - 20.00	95.00	92.00	0.28 (kg)	101	502097	20*	502092	
18.00 - 20.00	120.00	117.00	0.40 (kg)	101	502038	20*	502027		

\*Not suitable for indexable inserts with a radius of 0.031" (0.80 mm)

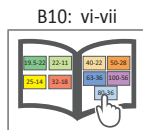
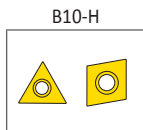
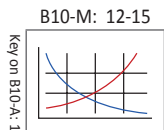

**i** = Imperial (in)  
**m** = Metric (mm)  
 Inserts sold separately

A  
B  
C  
D  
E  
F  
G  
H  
I  
J  
K  
L  
M  
INDEX

## Serrated Tool Bodies | Insert Holders

Steel | Carbide | Diameter Range: 0.787" - 1.260" (20.00 mm - 32.00 mm)

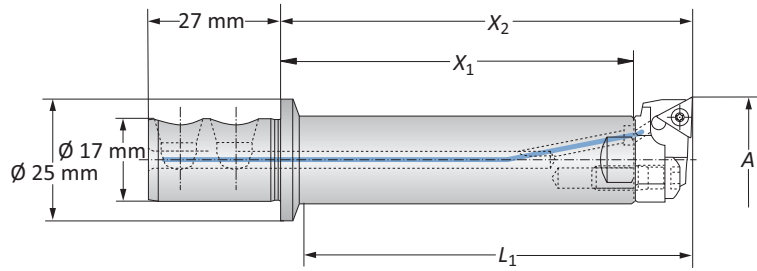

### Steel Serrated Tool Bodies

	Boring Range	Serrated Tool Body			Weight	Part No.
	A	X <sub>1</sub>	X <sub>2</sub>	L <sub>1</sub>		
<b>i</b>	0.787 - 1.260	2.835	3.307	3.031	0.441 (lbs)	<b>502045</b>
<b>m</b>	20.00 - 32.00	72.00	84.00	77.00	0.20 (kg)	<b>502045</b>

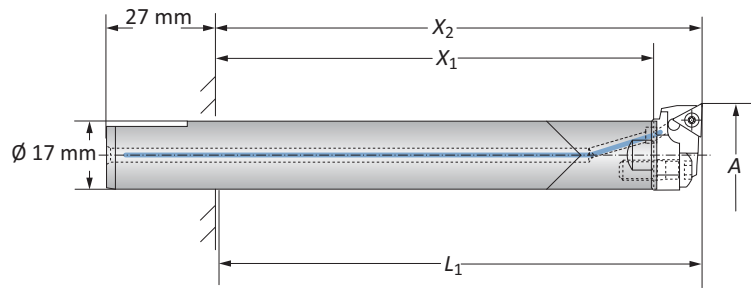

### Carbide Serrated Tool Bodies

	Boring Range	Serrated Tool Body			Weight	Part No.
	A	X <sub>1</sub>	X <sub>2</sub>	L <sub>1</sub>		
<b>i</b>	0.787 - 1.260	4.252	4.724	4.606	0.882 (lbs)	<b>502062</b>
<b>m</b>	20.00 - 32.00	108.00	120.00	117.00	0.40 (kg)	<b>502062</b>

### Insert Holders

	Boring Range	Insert Holder	Weight	Insert Form	Part No.	Insert Form	Part No.
	A	X <sub>1</sub>					
<b>i</b>	0.787 - 0.866	0.472	0.022 (lbs)	101	<b>502052</b>	20*	<b>502046</b>
	0.866 - 0.945	0.472	0.022 (lbs)	101	<b>502053</b>	20*	<b>502047</b>
	0.945 - 1.024	0.472	0.022 (lbs)	101	<b>502054</b>	20*	<b>502048</b>
	1.024 - 1.102	0.472	0.022 (lbs)	101	<b>502055</b>	20*	<b>502049</b>
	1.102 - 1.181	0.472	0.022 (lbs)	101	<b>502056</b>	20*	<b>502050</b>
	1.181 - 1.260	0.472	0.022 (lbs)	101	<b>502057</b>	20*	<b>502051</b>
<b>m</b>	20.00 - 22.00	12.00	0.01 (kg)	101	<b>502052</b>	20*	<b>502046</b>
	22.00 - 24.00	12.00	0.01 (kg)	101	<b>502053</b>	20*	<b>502047</b>
	24.00 - 26.00	12.00	0.01 (kg)	101	<b>502054</b>	20*	<b>502048</b>
	26.00 - 28.00	12.00	0.01 (kg)	101	<b>502055</b>	20*	<b>502049</b>
	28.00 - 30.00	12.00	0.01 (kg)	101	<b>502056</b>	20*	<b>502050</b>
	30.00 - 32.00	12.00	0.01 (kg)	101	<b>502057</b>	20*	<b>502051</b>

\*Not suitable for indexable inserts with a radius of 0.031" (0.80 mm)

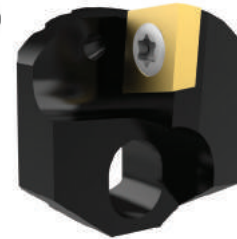

Form 101

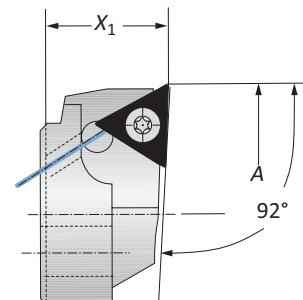

Form 20

Key on B10-A: 1

B10-M: 12-15

B10-A: 71

B10-H

B10: vi-vii

**i** = Imperial (in)  
**m** = Metric (mm)  
 Inserts sold separately

## Alu-Line Serrated Tool Bodies | Insert Holders

Diameter Range: 1.260" - 2.677" (32.00 mm - 68.00 mm)

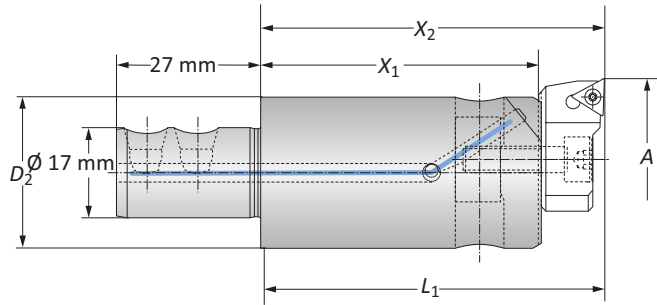

### Alu-Line Serrated Tool Bodies

	Boring Range	Serrated Tool Body				Weight	Part No.
	A	D <sub>2</sub>	X <sub>1</sub>	X <sub>2</sub>	L <sub>1</sub>		
i	1.260 - 1.968	1.122	2.047	2.598	2.480	0.220 (lbs)	501052
	1.260 - 1.968	1.122	3.465	4.016	3.898	0.441 (lbs)	501060
	1.968 - 2.677	1.811	2.402	2.953	2.835	0.441 (lbs)	501053
	1.968 - 2.677	1.811	4.173	4.724	4.606	0.661 (lbs)	501061
m	32.00 - 50.00	28.50	52.00	66.00	63.00	0.10 (kg)	501052
	32.00 - 50.00	28.50	88.00	102.00	99.00	0.20 (kg)	501060
	50.00 - 68.00	46.00	61.00	75.00	72.00	0.20 (kg)	501053
	50.00 - 68.00	46.00	106.00	120.00	117.00	0.30 (kg)	501061

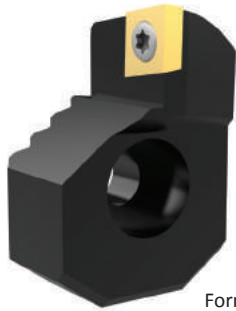

Form 101

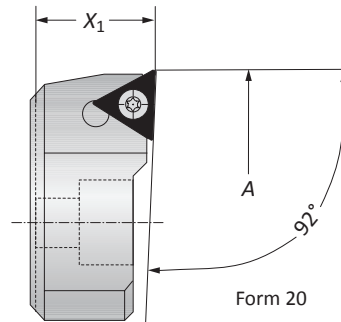

Form 20

### Insert Holders

	Serrated Tool Body	Boring Range	Insert Holder	Weight	Insert Form	Part No.
		A	X <sub>1</sub>			
i	501052 / 501060	1.260 - 1.614	0.551	0.066 (lbs)	20*	502060
		1.614 - 1.968	0.551	0.088 (lbs)	20*	502061
		1.260 - 1.614	0.551	0.066 (lbs)	101	502058
		1.614 - 1.968	0.551	0.088 (lbs)	101	502059
	501053 / 501061	1.968 - 2.323	0.551	0.066 (lbs)	20*	502060
		2.323 - 2.677	0.551	0.088 (lbs)	20*	502061
		1.968 - 2.323	0.551	0.066 (lbs)	101	502058
		2.323 - 2.677	0.551	0.088 (lbs)	101	502059
m	501052 / 501060	32.00 - 41.00	14.00	0.03 (kg)	20*	502060
		41.00 - 50.00	14.00	0.04 (kg)	20*	502061
		32.00 - 41.00	14.00	0.03 (kg)	101	502058
		41.00 - 50.00	14.00	0.04 (kg)	101	502059
	501053 / 501061	50.00 - 59.00	14.00	0.03 (kg)	20*	502060
		59.00 - 68.00	14.00	0.04 (kg)	20*	502061
		50.00 - 59.00	14.00	0.03 (kg)	101	502058
		59.00 - 68.00	14.00	0.04 (kg)	101	502059

\*Not suitable for indexable inserts with a radius of 0.031" (0.80 mm)

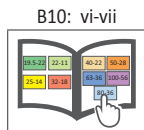
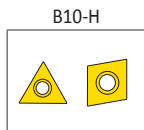
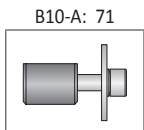
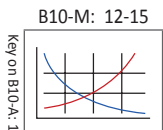

i = Imperial (in)  
m = Metric (mm)  
Inserts sold separately

A  
B  
C  
D  
E  
F  
G  
H  
I  
J  
K  
L  
M  
INDEX

## Alu-Line Serrated Slides | Insert Holders

Diameter Range: 2.667" - 8.189" (68.00 mm - 208.00 mm)

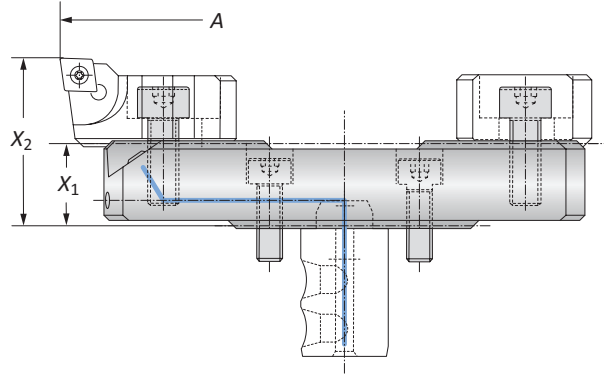

### Alu-Line Serrated Slides

	Boring Range	Serrated Slide		Weight	Part No.
	A	X <sub>1</sub>	X <sub>2</sub>		
i	2.667 - 3.780	0.630	1.280	0.220 (lbs)	501054
	3.780 - 4.881	0.630	1.280	0.220 (lbs)	501055
	4.881 - 5.984	0.630	1.280	0.441 (lbs)	501056
	5.984 - 7.088	0.866	1.516	0.551 (lbs)	501058
	7.088 - 8.189	0.866	1.516	0.661 (lbs)	501059
m	68.00 - 96.00	16.00	32.50	0.10 (kg)	501054
	96.00 - 124.00	16.00	32.50	0.10 (kg)	501055
	124.00 - 152.00	16.00	32.50	0.20 (kg)	501056
	152.00 - 180.00	22.00	38.50	0.25 (kg)	501058
	180.00 - 208.00	22.00	38.50	0.30 (kg)	501059

### Insert Holders

	Boring Range	Weight	Insert Form	Part No.
	A			
i	2.677 - 8.189	0.110 (lbs)	101	502064
	2.677 - 8.189	0.110 (lbs)	20	502069
m	68.00 - 208.00	0.05 (kg)	101	502064
	68.00 - 208.00	0.05 (kg)	20	502069

NOTE: Other insert holders available upon request



Form 20

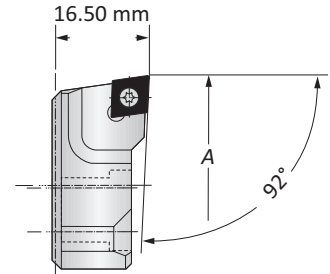

Form 101

### Counterweights

	Counterweight	Weight	Part No.
	X <sub>1</sub>		
i	0.528	0.110 (lbs)	502165
m	13.40	0.05 (kg)	502165

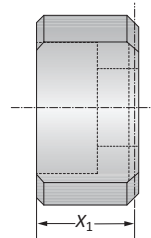

### Coolant Delivery Systems

	Coolant Delivery System	Part No.
	Weight	
i	0.044 (lbs)	501157
m	0.02 (kg)	501157

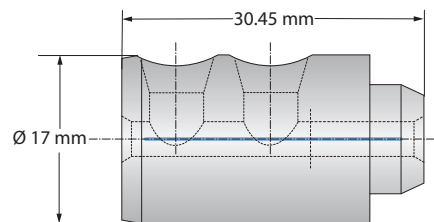

B10-M: 12-15

B10-A: 71

B10-H

B10: vi-vii

Key on B10-A: 1

i = Imperial (in)  
m = Metric (mm)

Inserts sold separately

## Outside Turning Insert Holders for Boring Heads

Diameter Range: 0.157" - 2.598" (4.00 mm - 66.00 mm)

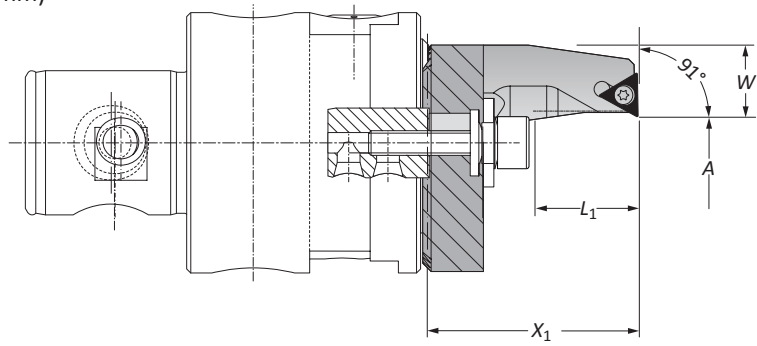

### Type A Insert Holders | Diameter Range: 0.157" - 1.181" (4.00 mm - 30.00 mm)

	Boring Range		Insert Holder			Weight	Insert Form	Part No.
	A	X <sub>1</sub>	L <sub>1</sub>	W				
i	0.157 - 0.689	1.594	0.787	0.653	0.220 (lbs)	20*	236081	
	0.650 - 1.181	1.988	1.181	0.437	0.220 (lbs)	20*	236082	
m	4.00 - 17.50	40.50	20.00	16.60	0.10 (kg)	20*	236081	
	16.50 - 30.00	50.50	30.00	11.10	0.10 (kg)	20*	236082	

NOTE: Clockwise and neutral execution

\*Not suitable for indexable inserts with a radius of 0.031" (0.80 mm)

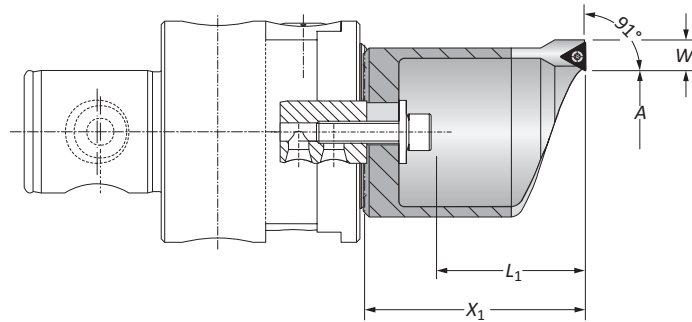

### Type B Insert Holders | Diameter Range: 1.142" - 2.598" (29.00mm - 66.00mm)

	Boring Range		Insert Holder			Weight	Insert Form	Part No.
	A	X <sub>1</sub>	L <sub>1</sub>	W				
i	1.142 - 1.732	2.952	2.126	0.377	0.661 (lbs)	20*	236083	
	1.693 - 2.598	3.956	3.110	0.377	0.882 (lbs)	20*	236084	
m	29.00 - 44.00	75.50	54.00	9.60	0.30 (kg)	20*	236083	
	43.00 - 66.00	100.50	79.00	9.60	0.40 (kg)	20*	236084	

NOTE: Clockwise and neutral execution

\*Not suitable for indexable inserts with a radius of 0.031" (0.80 mm)

### Clamping Pieces for Outside Turning Insert Holders

	Insert Holder Type	Boring Range	Service Key	Complete Part No.
m	A	4.00 - 30.00	s5	502080
	B	29.00 - 66.00	s5	502081

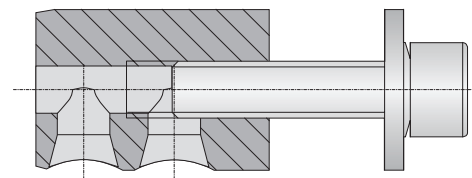

B10-M: 12-15

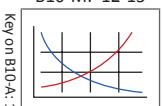

B10-A: 71

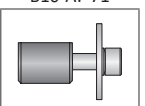

B10-H

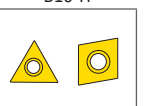

B10: vi-vii

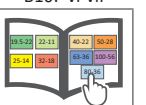

i = Imperial (in)  
m = Metric (mm)  
Inserts sold separately

A  
B  
C  
D  
E  
F  
G  
H  
I  
J  
K  
L  
M  
INDEX



## Outside Turning Serrated Slides | Insert Holders

Diameter Range: 0.078" - 4.488" (2.00 mm - 114.00 mm)

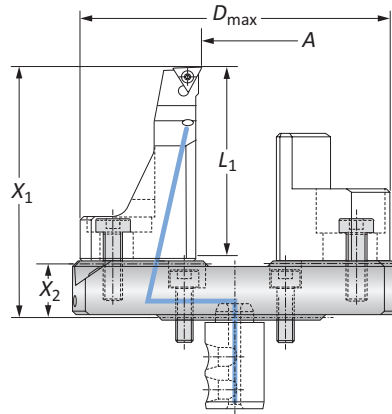
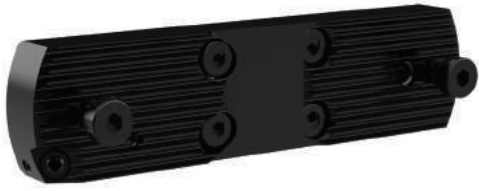

### Outside Turning Serrated Slides

	Boring Range		Serrated Slide			Weight	Part No.
	A	X <sub>1</sub>	X <sub>2</sub>	L <sub>1</sub>	D <sub>max</sub>		
i	0.078 - 1.181	2.874	0.630	2.165	3.396	0.771 (lbs)	501064
	1.181 - 2.283	2.874	0.630	2.165	5.078	0.970 (lbs)	501065
	2.283 - 3.385	3.110	0.866	2.165	6.181	1.322 (lbs)	501066
	3.385 - 4.488	3.110	0.866	2.165	7.283	1.609 (lbs)	501067
m	2.00 - 30.00	73.00	16.00	55.00	101.00	0.35 (kg)	501064
	30.00 - 58.00	73.00	16.00	55.00	129.00	0.44 (kg)	501065
	58.00 - 86.00	79.00	22.00	55.00	157.00	0.60 (kg)	501066
	86.00 - 114.00	79.00	22.00	55.00	185.00	0.73 (kg)	501067



### Outside Turning Insert Holders

	Outside Turning Range	Insert Holder	Weight	Insert Form	Part No.
	A	X <sub>1</sub>			
i	0.079 - 4.488	2.244	0.331 (lbs)	20	502082
m	2.00 - 114.00	57.00	0.15 (kg)	20	502082

NOTE: Clockwise and neutral execution

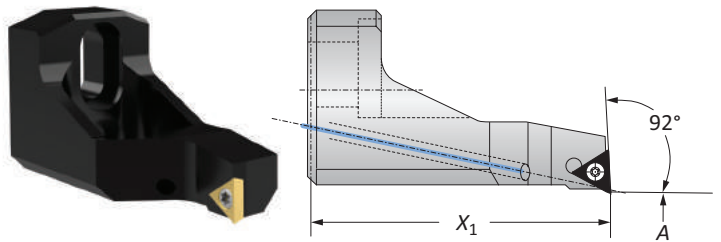

### Counterweights

	Counterweight		Part No.
	X <sub>1</sub>	Weight	
i	1.486	0.352 (lbs)	502183
m	37.75	0.16 (kg)	502183

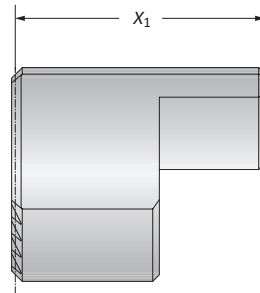

### Coolant Delivery Systems

	Weight	Part No.
i	0.044 (lbs)	501157
m	0.02 (kg)	501157

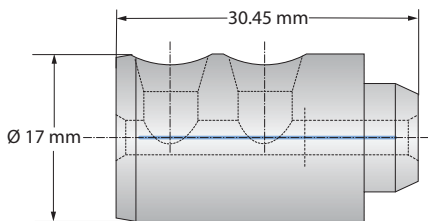

Key on B10-A: 1

B10-M: 12-15

B10-A: 71

B10-H

B10: vi-vii

i = Imperial (in)  
m = Metric (mm)  
Inserts sold separately

Accessories

No.	Part	Size	Part No.
1	Set screw	s3	415244
2	Screw for securing insert holder	T25	415112
3	Clamping piece	-	145184
4	Cap screw for securing insert holders	s4	027154
5	Cap screw for securing insert holder/ counterweight	s4	315248
6	Set screw - coolant	501054, 501055, 501056	s1.5 114224
		501058, 501059	s1.5 115303
7	Cap screw for securing serrated slide	s4	115166
8	Sealing ring for coolant delivery	-	415386

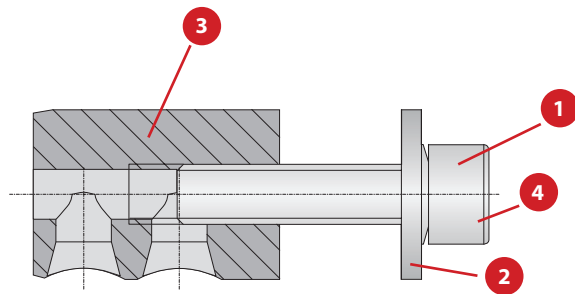
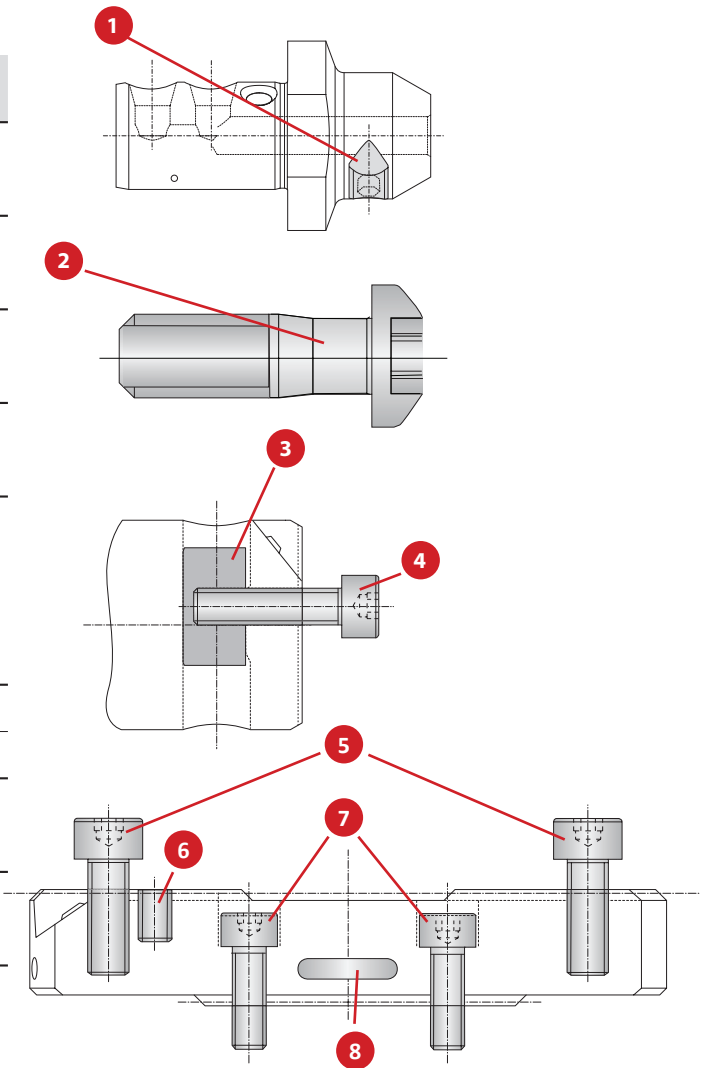

	Boring Range	Type	Hex Size	Clamping Screw Parts				Complete Part No.
				1 Cap Screw	2 Washer	3 Clamping Piece	4 Locking Washer	
i	0.157 - 1.181	A	s5	070153	315155	502180	215254	502080
	1.142 - 2.598	B	s5	070153	315156	502180	215254	502081
m	4.00 - 30.00	A	s5	070153	315155	502180	215254	502080
	29.00 - 66.00	B	s5	070153	315156	502180	215254	502081

A  
B  
C  
D  
E  
F  
G  
H  
I  
J  
K  
L  
M  
INDEX

Accessories

No.	Part	Insert Form	Size	Part No.
1	Clamping screw	-	-	415353
2	Set screw for clamping tool	-	-	215674
3	Battery cover	-	-	415895
4	Battery*	-	-	415896
5	Battery access cover with sealing ring	-	-	501016
6	Insert screws	Form 211 Form 20 Form 101	T6 T7 T8	215377 115535 115676
7	Hex driver	-	s1.5 s3	215472 115630
8	Hex driver	-	s4	115576
9	Torx® driver	-	T6 T7 T8 T20	115537 115591 115590 215150
10	Torque screwdriver, Torx	(0.6 Nm) Form 211 (0.9 Nm) Form 20 (1.2 Nm) Form 101	T6 T7 T8	415507 415508 415514

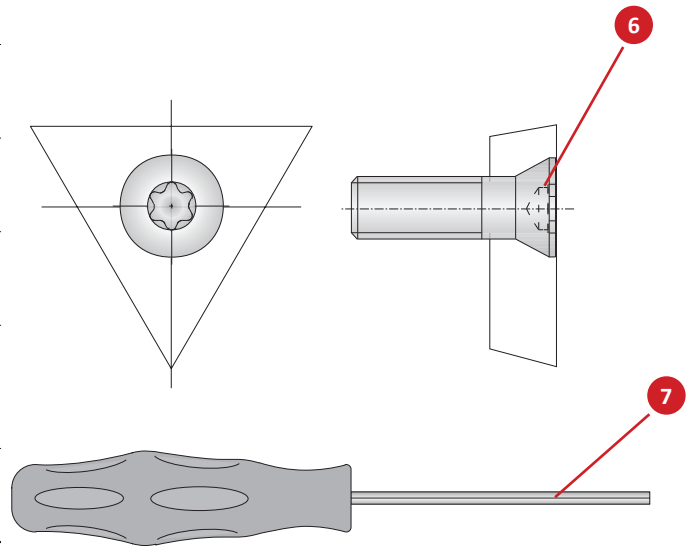
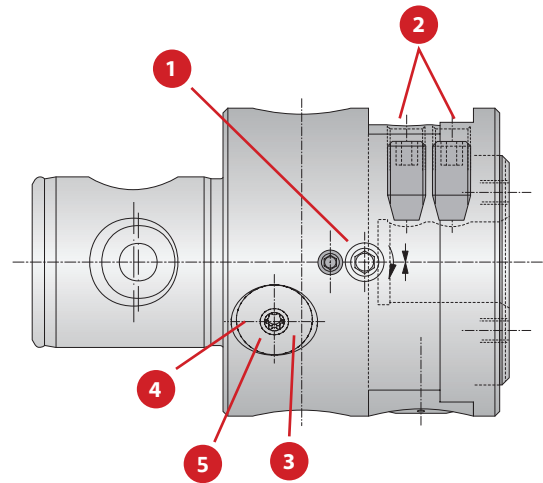

\*Always change two batteries  
**NOTE:** Please use VARTA batteries (V392 SR41)

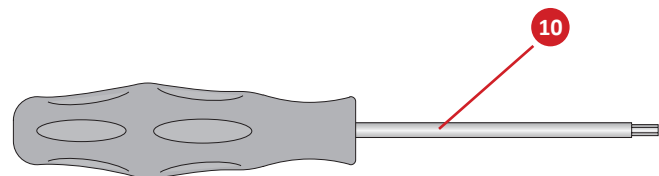
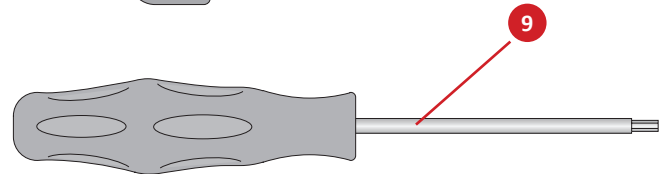
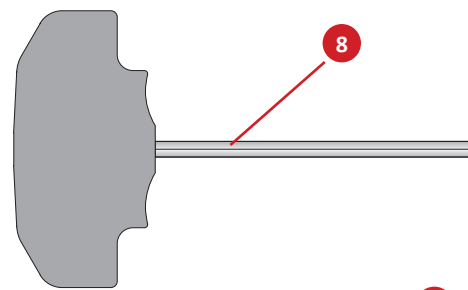

## Kit Components

Insert Form 101 | Diameter Range: 0.394" - 1.260" (10.00 mm - 32.00 mm)

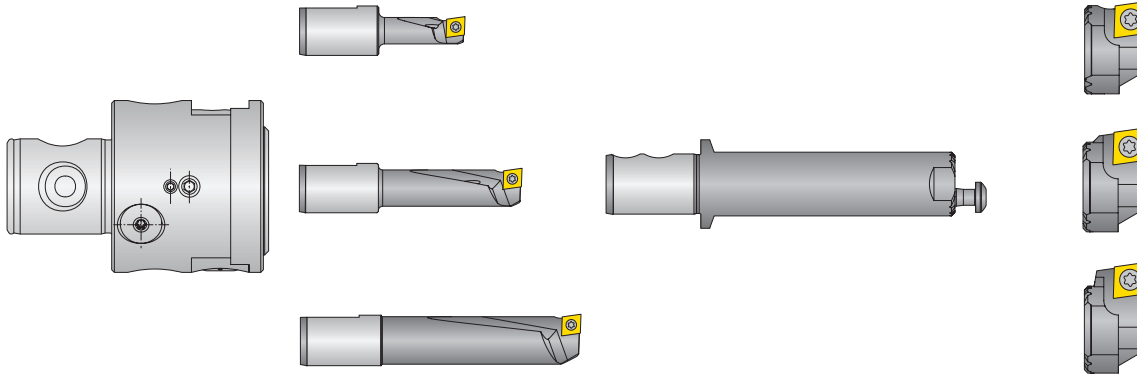

Diameter Range: 0.394" - 1.260" (10.00 mm - 32.00 mm)

	Boring Head	Boring Range	Kit Components				Kit No.	
			Boring Bars	Boring Range	Serrated Tool Body	Insert Holders		Service Keys
<b>i</b>	504001	0.394 - 0.433 0.551 - 0.591 0.709 - 0.748	502012 502014 502016	0.787 - 1.260	502045	502052 502054 502056	115576 (s4) 415121 (T25) 115590 (T8)	<b>104061</b>
<b>m</b>	501001	10.00 - 11.00 14.00 - 15.00 18.00 - 19.00	502012 502014 502016	20.00 - 32.00	502045	502052 502054 502056	115576 (s4) 415121 (T25) 115590 (T8)	<b>103061</b>

**NOTE:** Inserts sold separately

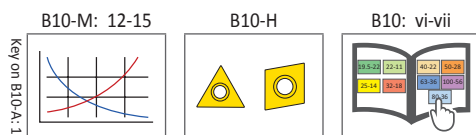

**i** = Imperial (in)  
**m** = Metric (mm)  
Inserts sold separately

**IMPORTANT:** Max spindle speed refers to maximum possible speed for an individual boring head and is not a recommended parameter. Refer to page B10-M: 12 for recommended application-specific parameters. Factory technical assistance is available for your specific applications through our Application Engineering department.  
ext: 7611 | email: [appeng@alliedmachine.com](mailto:appeng@alliedmachine.com)

A  
B  
C  
D  
E  
F  
G  
H  
I  
J  
K  
L  
M  
INDEX

## Kit Components

Insert Form 20 | Diameter Range: 0.394" - 1.260" (10.00 mm - 32.00 mm)

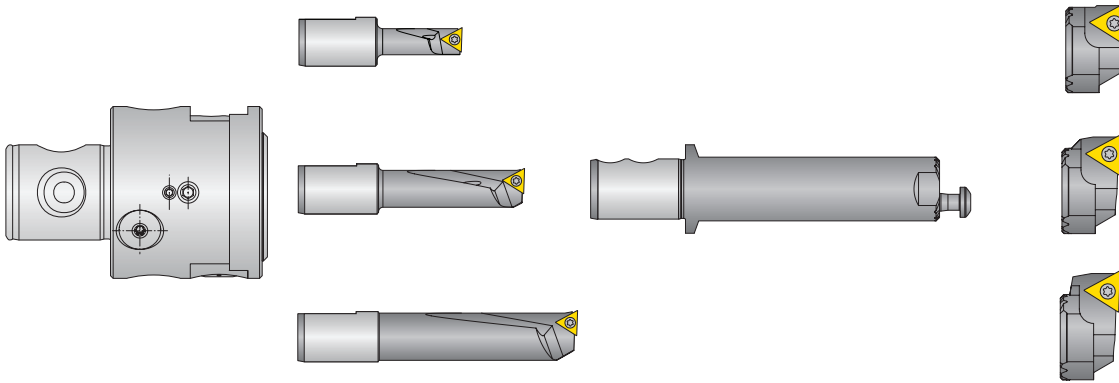

Diameter Range: 0.394" - 1.260" (10.00 mm - 32.00 mm)

		Kit Components						
	Boring Head	Boring Range	Boring Bars	Boring Range	Serrated Tool Body	Insert Holders	Service Keys	Kit No.
<b>i</b>	504001	0.394 - 0.433 0.551 - 0.591 0.709 - 0.748	502001 502003 502005	0.787 - 1.260	502045	502046 502048 502050	115576 (s4) 415121 (T25) 115591 (T7)	<b>104062</b>
<b>m</b>	501001	10.00 - 11.00 14.00 - 15.00 18.00 - 19.00	502001 502003 502005	20.00 - 32.00	502045	502046 502048 502050	115576 (s4) 415121 (T25) 115591 (T7)	<b>103062</b>

NOTE: Inserts sold separately



B10-M: 12-15 | B10-H | B10: vi-vii

**i** = Imperial (in)  
**m** = Metric (mm)

Inserts sold separately

**IMPORTANT:** Max spindle speed refers to maximum possible speed for an individual boring head and is not a recommended parameter. Refer to page B10-M: 12 for recommended application-specific parameters. Factory technical assistance is available for your specific applications through our Application Engineering department.  
ext: 7611 | email: [appeng@alliedmachine.com](mailto:appeng@alliedmachine.com)



## Kit Components

Insert Form 101 | Diameter Range: 1.260" - 2.677" (32.00 mm - 68.00 mm)

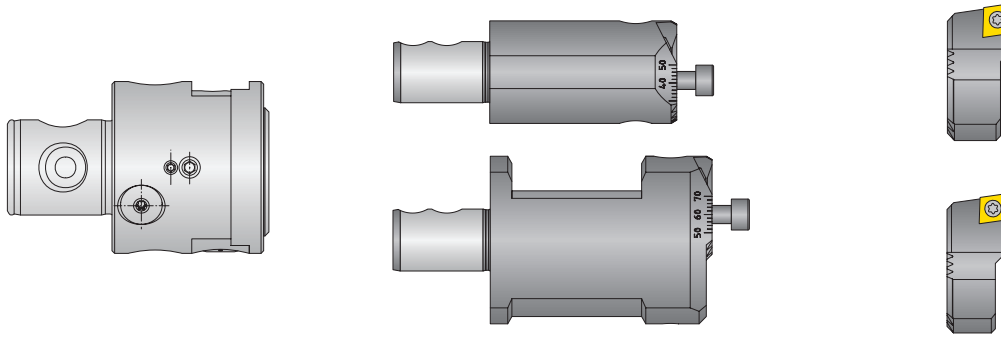

Diameter Range: 1.260" - 2.677" (32.00 mm - 68.00 mm)

	Boring Head	Kit Components				Kit No.
		Boring Range	Serrated Tool Body	Insert Holders	Service Keys	
i	504001	1.260 - 1.968	501052	502058	115576 (s4)	104063
		1.968 - 2.677	501053	502059	115590 (T8)	
m	501001	32.00 - 50.00	501052	502058	115576 (s4)	103063
		50.00 - 68.00	501053	502059	115590 (T8)	

NOTE: Inserts sold separately

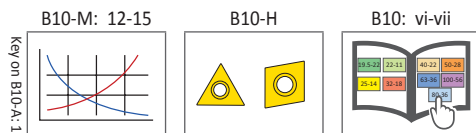

i = Imperial (in)  
m = Metric (mm)  
Inserts sold separately

**IMPORTANT:** Max spindle speed refers to maximum possible speed for an individual boring head and is not a recommended parameter. Refer to page B10-M: 12 for recommended application-specific parameters. Factory technical assistance is available for your specific applications through our Application Engineering department.  
ext: 7611 | email: [appeng@alliedmachine.com](mailto:appeng@alliedmachine.com)

A  
B  
C  
D  
E  
F  
G  
H  
I  
J  
K  
L  
M  
INDEX

## Kit Components

Insert Form 20 | Diameter Range: 1.260" - 2.677" (32.00 mm - 68.00 mm)

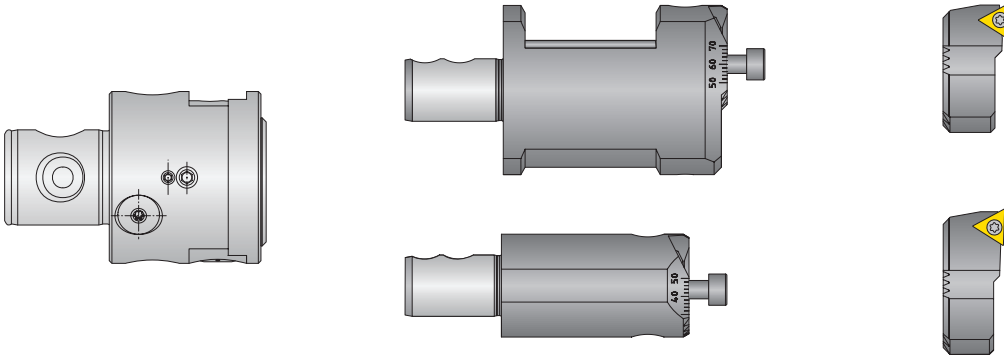

Diameter Range: 1.260" - 2.677" (32.00 mm - 68.00 mm)

		Kit Components				
	Boring Head	Boring Range	Serrated Tool Body	Insert Holders	Service Keys	Kit No.
i	504001	1.260 - 1.968	501052	502060	115576 (s4)	104064
		1.968 - 2.677	501053	502061	115591 (T7)	
m	501001	32.00 - 50.00	501052	502060	115576 (s4)	103064
		50.00 - 68.00	501053	502061	115591 (T7)	

NOTE: Inserts sold separately

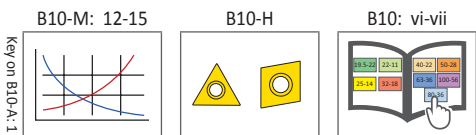

i = Imperial (in)  
m = Metric (mm)

Inserts sold separately

**IMPORTANT:** Max spindle speed refers to maximum possible speed for an individual boring head and is not a recommended parameter. Refer to page B10-M: 12 for recommended application-specific parameters. Factory technical assistance is available for your specific applications through our Application Engineering department.  
ext: 7611 | email: [appeng@alliedmachine.com](mailto:appeng@alliedmachine.com)

## Kit Components

Insert Form 101 | Diameter Range: 2.667" - 5.984" (68.00 mm - 152.00 mm)

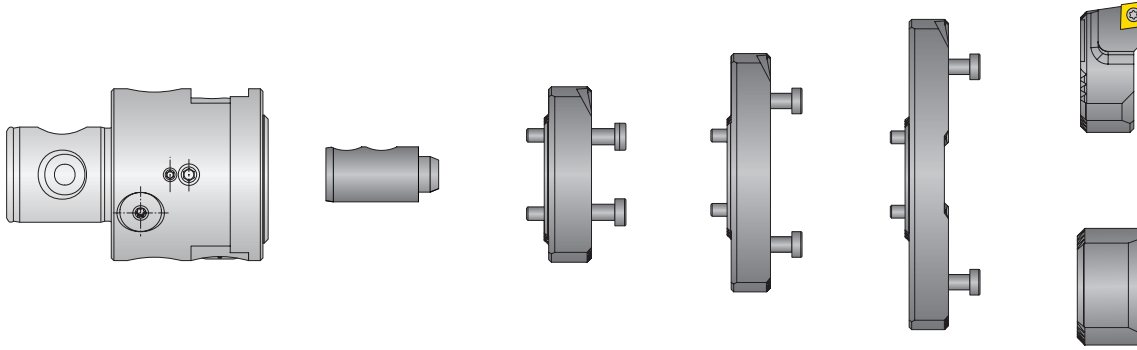

Diameter Range: 2.667" - 5.984" (68.00 mm - 152.00 mm)

		Kit Components						
	Boring Head	Boring Range	Serrated Slides	Insert Holder	Counterweight	Coolant Delivery	Service Keys	Kit No.
<b>i</b>	504001	2.667 - 3.780	501054	502064	502165	501157	115576 (s4)	<b>104065</b>
		3.780 - 4.881	501055				115590 (T8)	
		4.881 - 5.984	501056					
<b>m</b>	501001	68.00 - 96.00	501054	502064	502165	501157	115576 (s4)	<b>103065</b>
		96.00 - 124.00	501055				115590 (T8)	
		124.00 - 152.00	501056					

**NOTE:** Inserts sold separately

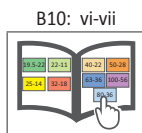
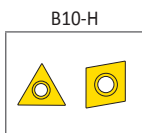
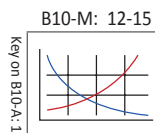

**i** = Imperial (in)  
**m** = Metric (mm)  
 Inserts sold separately

**IMPORTANT:** Max spindle speed refers to maximum possible speed for an individual boring head and is not a recommended parameter. Refer to page B10-M: 12 for recommended application-specific parameters. Factory technical assistance is available for your specific applications through our Application Engineering department.  
 ext: 7611 | email: [appeng@alliedmachine.com](mailto:appeng@alliedmachine.com)

A  
B  
C  
D  
E  
F  
G  
H  
I  
J  
K  
L  
M  
INDEX

## Kit Components

Insert Form 20 | Diameter Range: 2.667" - 5.984" (68.00 mm - 152.00 mm)

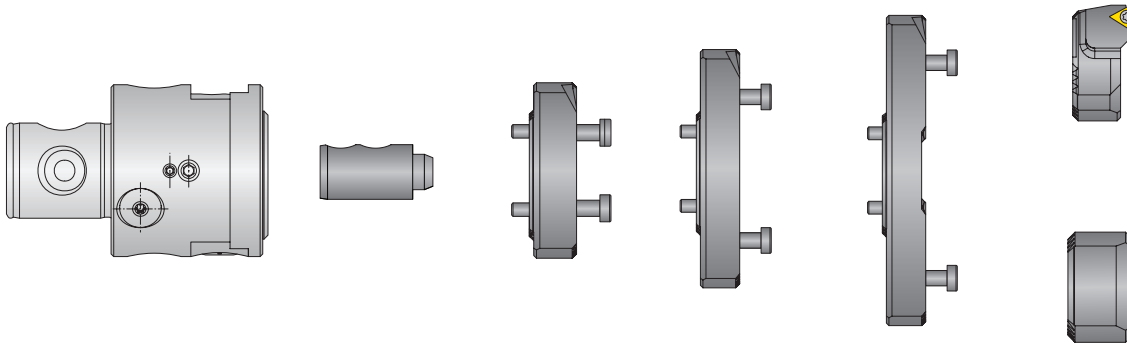

Diameter Range: 2.667" - 5.984" (68.00 mm - 152.00 mm)

		Kit Components						
	Boring Head	Boring Range	Serrated Slides	Insert Holder	Counterweight	Coolant Delivery	Service Keys	Kit No.
i	504001	2.667 - 3.780	501054	502069	502165	501157	115576 (s4)	104066
		3.780 - 4.881	501055				115591 (T7)	
		4.881 - 5.984	501056					
m	501001	68.00 - 96.00	501054	502069	502165	501157	115576 (s4)	103066
		96.00 - 124.00	501055				115591 (T7)	
		124.00 - 152.00	501056					

NOTE: Inserts sold separately

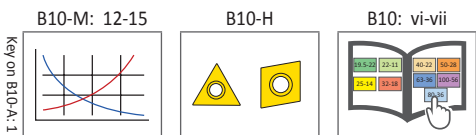

i = Imperial (in)  
m = Metric (mm)

Inserts sold separately

**IMPORTANT:** Max spindle speed refers to maximum possible speed for an individual boring head and is not a recommended parameter. Refer to page B10-M: 12 for recommended application-specific parameters. Factory technical assistance is available for your specific applications through our Application Engineering department.  
ext: 7611 | email: [appeng@alliedmachine.com](mailto:appeng@alliedmachine.com)

## Kit Components

Insert Form 101 | Diameter Range: 3.780" - 8.189" (96.00 mm - 208.00 mm)

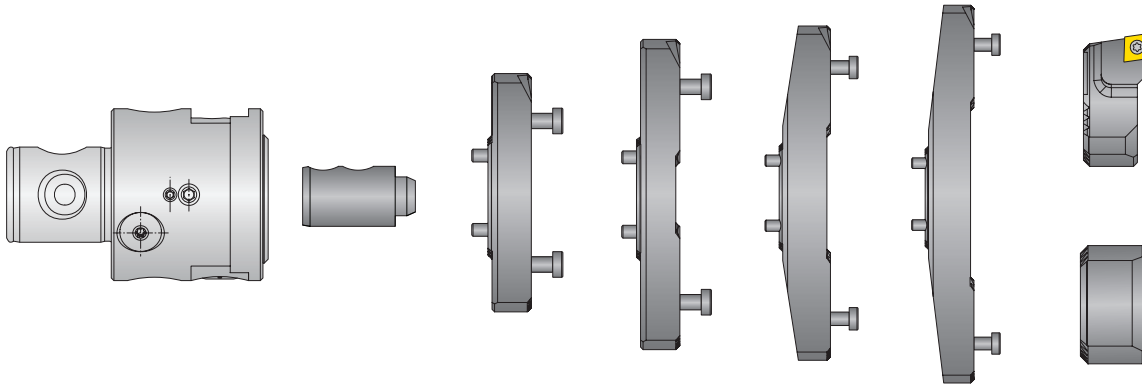

Diameter Range: 3.780" - 8.189" (96.00 mm - 208.00 mm)

		Kit Components						
	Boring Head	Boring Range	Serrated Slides	Insert Holder	Counterweight	Coolant Delivery	Service Keys	Kit No.
i	504001	3.780 - 4.881	501055	502064	502165	501157	115576 (s4) 115590 (T8)	104081
		4.881 - 5.984	501056					
		5.984 - 7.088	501058					
		7.088 - 8.189	501059					
m	501001	96.00 - 124.00	501055	502064	502165	501157	115576 (s4) 115590 (T8)	103081
		124.00 - 152.00	501056					
		152.00 - 180.00	501058					
		180.00 - 208.00	501059					

NOTE: Inserts sold separately



B10-M: 12-15

Key on B10-A-1

B10-H

B10: vi-vii

i = Imperial (in)  
m = Metric (mm)  
Inserts sold separately

**IMPORTANT:** Max spindle speed refers to maximum possible speed for an individual boring head and is not a recommended parameter. Refer to page B10-M: 12 for recommended application-specific parameters. Factory technical assistance is available for your specific applications through our Application Engineering department.  
ext: 7611 | email: [appeng@alliedmachine.com](mailto:appeng@alliedmachine.com)

A  
B  
C  
D  
E  
F  
G  
H  
I  
J  
K  
L  
M  
INDEX



## Kit Components

Insert Form 20 | Diameter Range: 3.780" - 8.189" (96.00 mm - 208.00 mm)

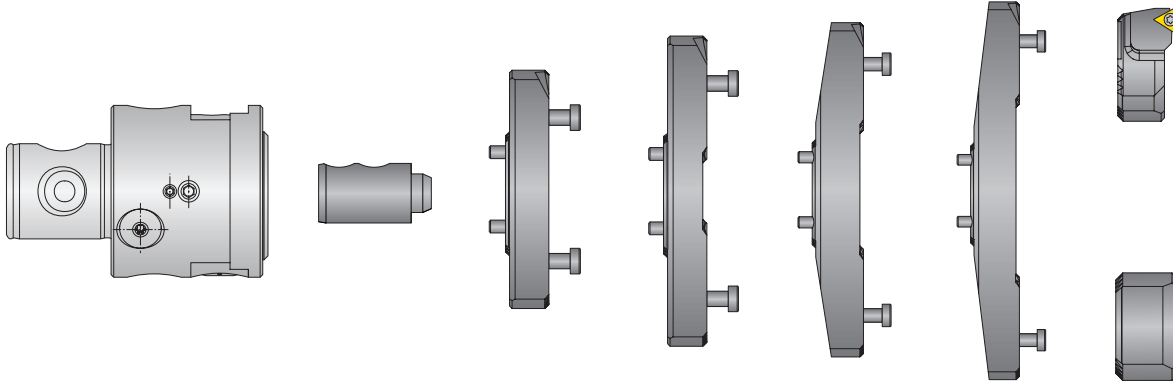

Diameter Range: 3.780" - 8.189" (96.00 mm - 208.00 mm)

		Kit Components						
	Boring Head	Boring Range	Serrated Slides	Insert Holder	Counterweight	Coolant Delivery	Service Keys	Kit No.
i	504001	3.780 - 4.881	501055	502069	502165	501157	115576 (s4) 115591 (T7)	104080
		4.881 - 5.984	501056					
		5.984 - 7.088	501058					
		7.088 - 8.189	501059					
m	501001	96.00 - 124.00	501055	502069	502165	501157	115576 (s4) 115591 (T7)	103080
		124.00 - 152.00	501056					
		152.00 - 180.00	501058					
		180.00 - 208.00	501059					

NOTE: Inserts sold separately



B10-M: 12-15

B10-H

B10: vi-vii

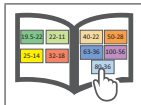
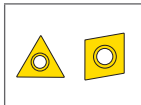
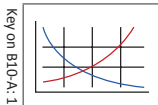

i = Imperial (in)  
m = Metric (mm)

Inserts sold separately

**IMPORTANT:** Max spindle speed refers to maximum possible speed for an individual boring head and is not a recommended parameter. Refer to page B10-M: 12 for recommended application-specific parameters. Factory technical assistance is available for your specific applications through our Application Engineering department.  
ext: 7611 | email: [appeng@alliedmachine.com](mailto:appeng@alliedmachine.com)



# Guaranteed Test / Demo Application Form

Distributor PO # \_\_\_\_\_

The following must be filled out completely before your test will be considered

**IMPORTANT:** For processing, send Purchase Order to your Allied Field Sales Engineer (FSE). Please clearly mark the paperwork as "Test Order."

## Distributor Information

Company Name: \_\_\_\_\_  
 Contact: \_\_\_\_\_  
 Account Number: \_\_\_\_\_  
 Phone: \_\_\_\_\_  
 Email: \_\_\_\_\_

## End User Information

Company Name: \_\_\_\_\_  
 Contact: \_\_\_\_\_  
 Industry: \_\_\_\_\_  
 Phone: \_\_\_\_\_  
 Email: \_\_\_\_\_

**Current Process** List all tooling, coatings, substrates, speeds and feeds, tool life, and any problems you are experiencing

\_\_\_\_\_

\_\_\_\_\_

**Test Objective** List what would make this a successful test (i.e. penetration rate, finish, tool life, hole size, etc.)

\_\_\_\_\_

\_\_\_\_\_

## Application Information

Hole Diameter: _____ in/mm	Tolerance: _____	Material: _____ (4150 / A36 / Cast Iron / etc.)
Preexisting Diameter: _____ in/mm	Depth of Cut: _____ in/mm	Hardness: _____ (BHN / Rc)
Required Finish: _____ RMS	State: _____	(Casting / Hot rolled / Forging)

## Machine Information

Machine Type: _____ (Lathe / Screw machine / Machine center / etc.)	Builder: _____ (Haas, Mori Seiki, etc.)	Model #: _____
Shank Required: _____ (CAT50 / Morse taper, etc.)		Power: _____ HP/KW
Rigidity: _____	Orientation: _____	Tool Rotating: _____
<input type="checkbox"/> Excellent	<input type="checkbox"/> Vertical	<input type="checkbox"/> Yes
<input type="checkbox"/> Good	<input type="checkbox"/> Horizontal	<input type="checkbox"/> No
<input type="checkbox"/> Poor		Thrust: _____ lbs/N

## Coolant Information

Coolant Delivery: _____ (Through tool / Flood)	Coolant Pressure: _____ PSI / bar
Coolant Type: _____ (Air mist, oil, synthetic, water soluble, etc.)	Coolant Volume: _____ GPM / LPM

## Requested Tooling

QTY	Item Number	QTY	Item Number



**Allied Machine & Engineering**  
 120 Deeds Drive  
 Dover, OH 44622

Telephone: (330) 343-4283  
 Toll Free USA & Canada: (800) 321-5537  
 Fax: (330) 602-3400  
 Email: info@alliedmachine.com

## Warranty Information



Allied Machine & Engineering ("Allied Machine") warrants to original equipment manufacturers, distributors, industrial and commercial users of its products for one year from the original date of sale that each new product manufactured or supplied by Allied Machine shall be free from defects in material and workmanship.

Allied Machine's sole and exclusive obligation under this warranty is limited to, at its option, without additional charge, replacing or repairing this product or issuing a credit. For this warranty to be applied, the product must be returned freight prepaid to the plant designated by an Allied Machine representative and which, upon inspection, is determined by Allied Machine to be defective in material and workmanship.

Complete information as to operating conditions, machine, setup, and the application of cutting fluid should accompany any product returned for inspection. This warranty shall not apply to any Allied Machine products which have been subjected to misuse, abuse, improper operating conditions, improper machine setup or improper application of cutting fluid or which have been repaired or altered if such repair or alteration, in the judgement of Allied Machine, would adversely affect the performance of the product.

THIS WARRANTY IS IN LIEU OF ALL OTHER WARRANTIES, EXPRESS OR IMPLIED, INCLUDING ANY IMPLIED WARRANTY OF MERCHANTABILITY OR FITNESS FOR A PARTICULAR PURPOSE. Allied Machine shall have no liability or responsibility for any claim, whether in contract, tort or otherwise, for any loss or damage arising out of, connected with, or resulting from the manufacture, sale, delivery or use of any product sold hereunder, in excess of the cost of replacement or repair as provided herein.

Allied Machine shall not be liable in contract or in tort (including, without limitation, negligence, strict liability or otherwise) for economic losses of any kind or for any special, incidental, indirect, consequential, punitive or exemplary damages arising in any way out of the performance of, or failure to perform this agreement.

ALL PRICES, DELIVERIES, DESIGNS, AND MATERIALS ARE SUBJECT TO CHANGE WITHOUT NOTICE.



Allied Machine & Engineering  
is registered to  
ISO 9001:2015 by DQS



Wohlhaupter GmbH  
is registered to  
ISO 9001:2015 by QA TECHNIC

## United States

**Allied Machine & Engineering**  
120 Deeds Drive  
Dover OH 44622  
United States

**Phone:**  
+1.330.343.4283

**Fax:**  
+1.330.602.3400

**Toll Free USA and Canada:**  
800.321.5537

**Toll Free USA and Canada:**  
800.223.5140

**Allied Machine & Engineering**  
485 W Third Street  
Dover OH 44622  
United States

**Phone:**  
+1.330.343.4283

**Fax:**  
+1.330.364.7666  
(Engineering Dept.)

**Toll Free USA and Canada:**  
800.321.5537

## Europe

**Allied Machine & Engineering Co. (Europe) Ltd.**  
93 Vantage Point  
Pensnett Estate  
Kingswinford  
West Midlands  
DY6 7FR England

**Phone:**  
+44 (0) 1384.400900

**Wohlhaupter GmbH**  
Maybachstrasse 4  
Postfach 1264  
72636 Frickenhausen  
Germany

**Phone:**  
+49 (0) 7022.408.0

**Fax:**  
+49 (0) 7022.408.212

## Asia

**Wohlhaupter India Pvt. Ltd.**  
B-23, 3rd Floor  
B Block Community Centre  
Janakpuri, New Delhi - 110058  
India

**Phone:**  
+91 (0) 11.41827044

Your local Allied Machine representative:

[www.alliedmachine.com](http://www.alliedmachine.com)

Allied Machine & Engineering is registered to **ISO 9001:2015** by DQS  
Wohlhaupter GmbH is registered to **ISO 9001:2015** by QTA TECHNIC

